



Build your own Refrigeration Plant



Sponsored by
FJB 

Parts of the Refrigeration Plant

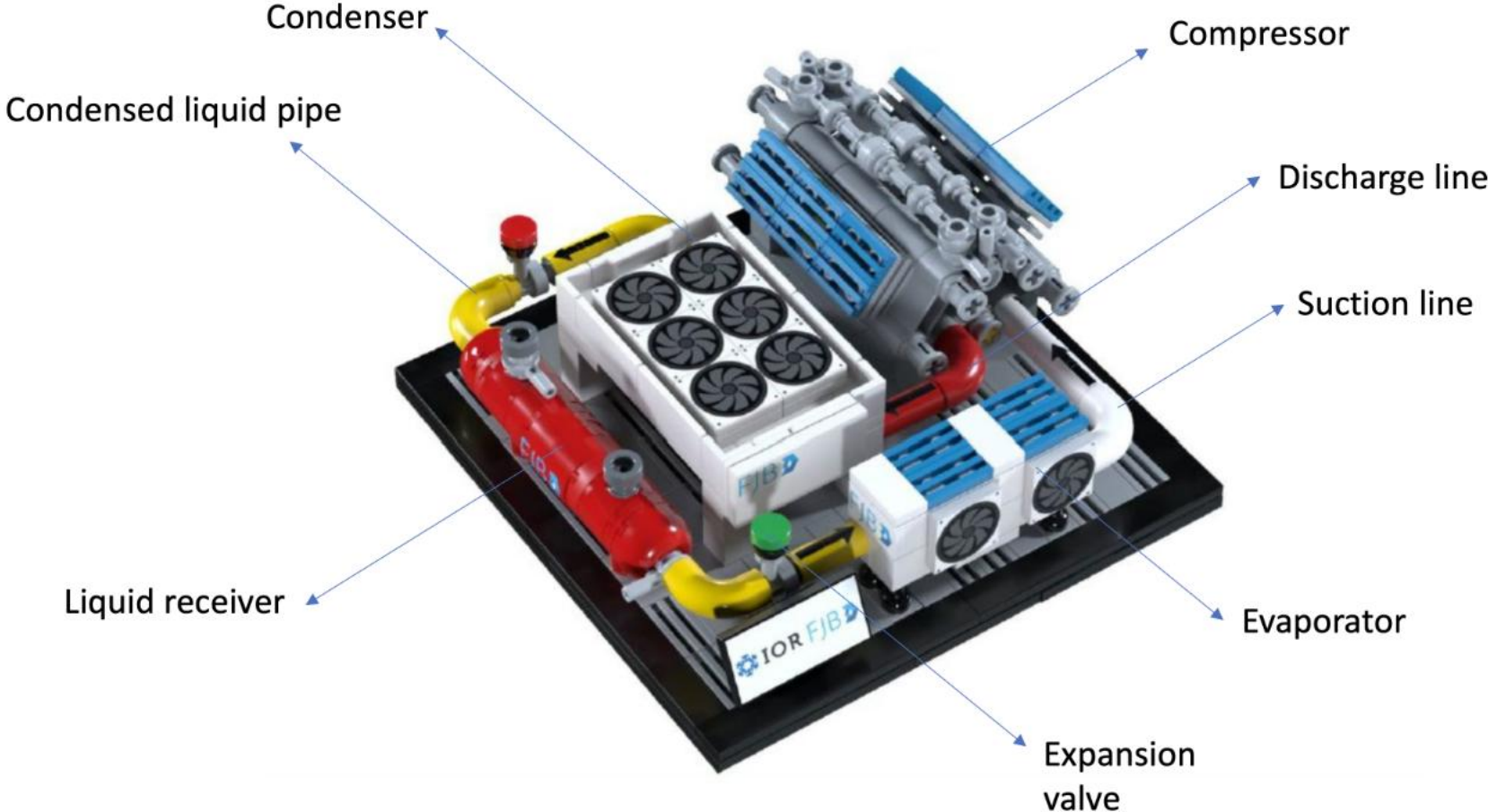

What is a Refrigeration Cycle & how does it work?

In its simplest terms the Refrigeration Cycle relies on the Refrigerant (a special substance) changing between two phases - gas and liquid. This is known as a 'Change of State', which occurs when heat is either rejected or absorbed from the Refrigerant. During the Refrigeration Cycle the Refrigerant will go through four processes: compression, condensation, expansion and evaporation to 'change its state'.

As the refrigerant gas is **compressed** its pressure and temperature increases, so that it can be **condensed** into its liquid form (a change of state). During **the condensation process** heat is rejected from the refrigerant to the 'outside air' which causes the gas to cool and condense into a liquid.

The liquid is then **expanded** to create a low pressure liquid and gas mixture (aerosol) which then **evaporates** back into a low pressure gas (a change of state). During the **evaporation process** heat is transferred (absorbed) from the 'inside air' to the refrigerant creating a 'cooling effect'. It is a 'cooling effect' because the air is not cooled as such, but rather the heat is removed leaving only the cool air which creates the cold environment. And then the cycle repeats itself.

These processes take place in the Compressor, the Condenser, the Expansion Valve and the Evaporator. These components make up the Refrigeration Plant and will be explained as you build each component.

For more information visit: <https://www.fantasticfridges.com/CoolingScience/HowDoesAFridgeWorkAdvanced>

The Refrigeration Cycle – Four Main Processes

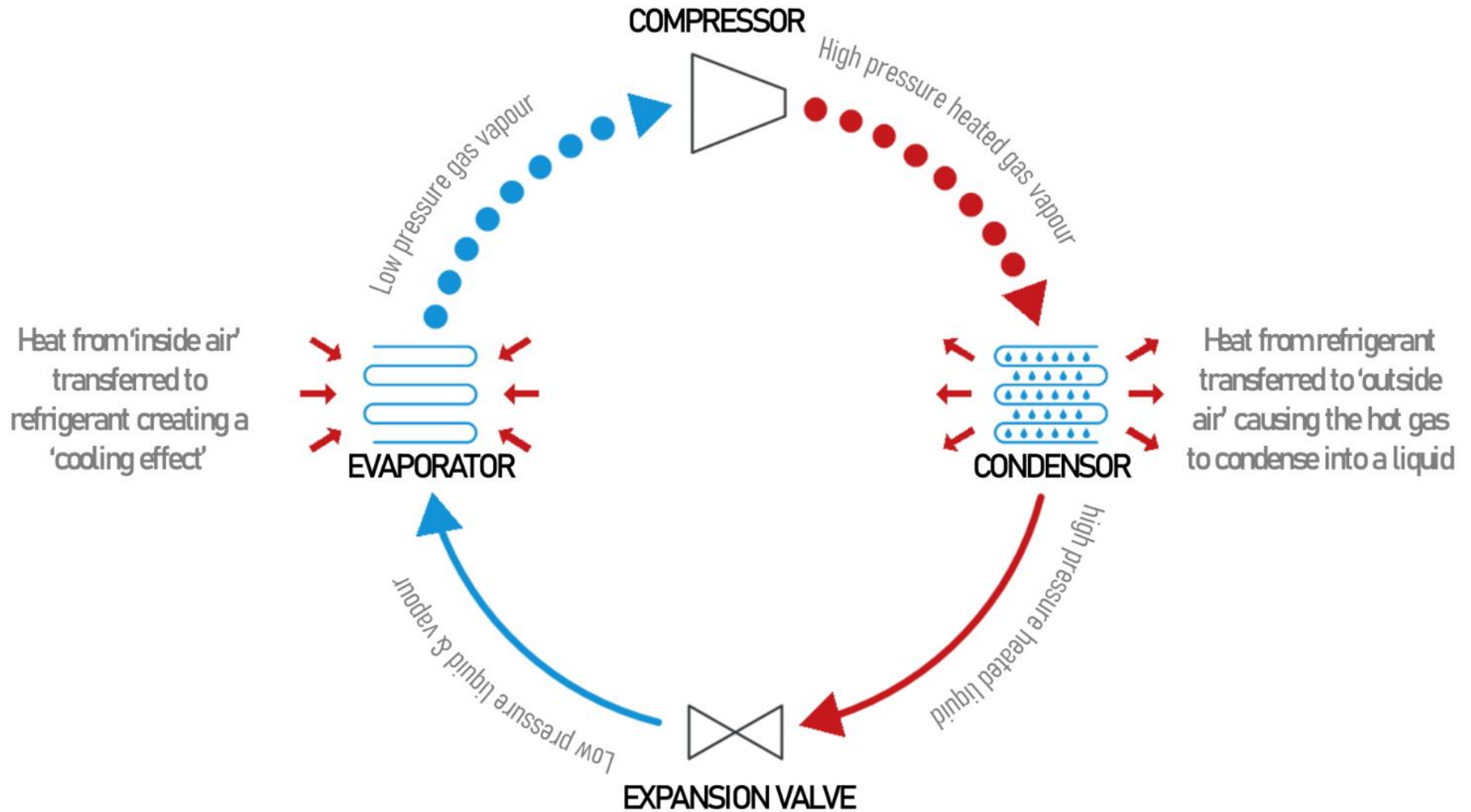

1

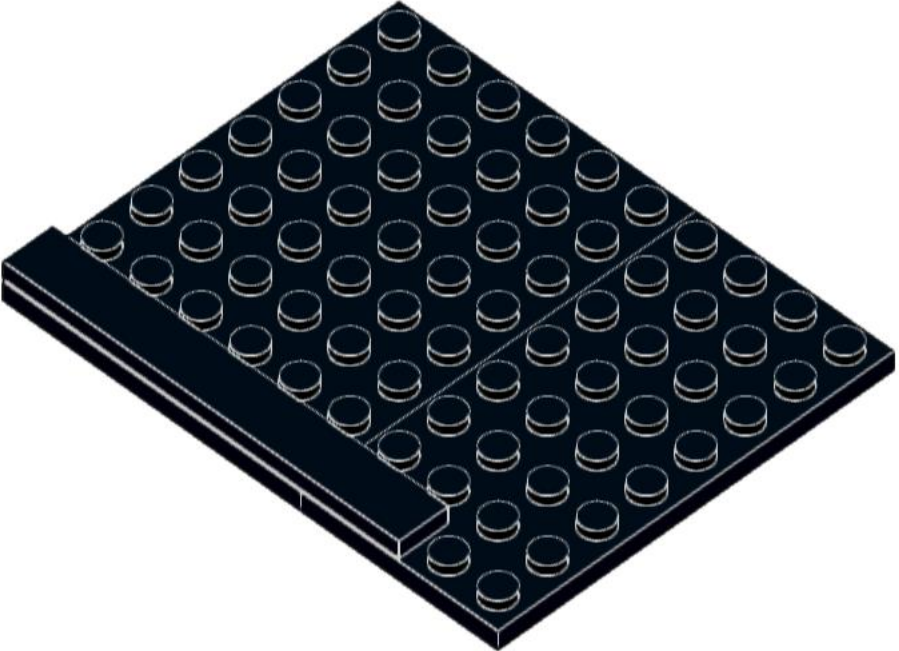
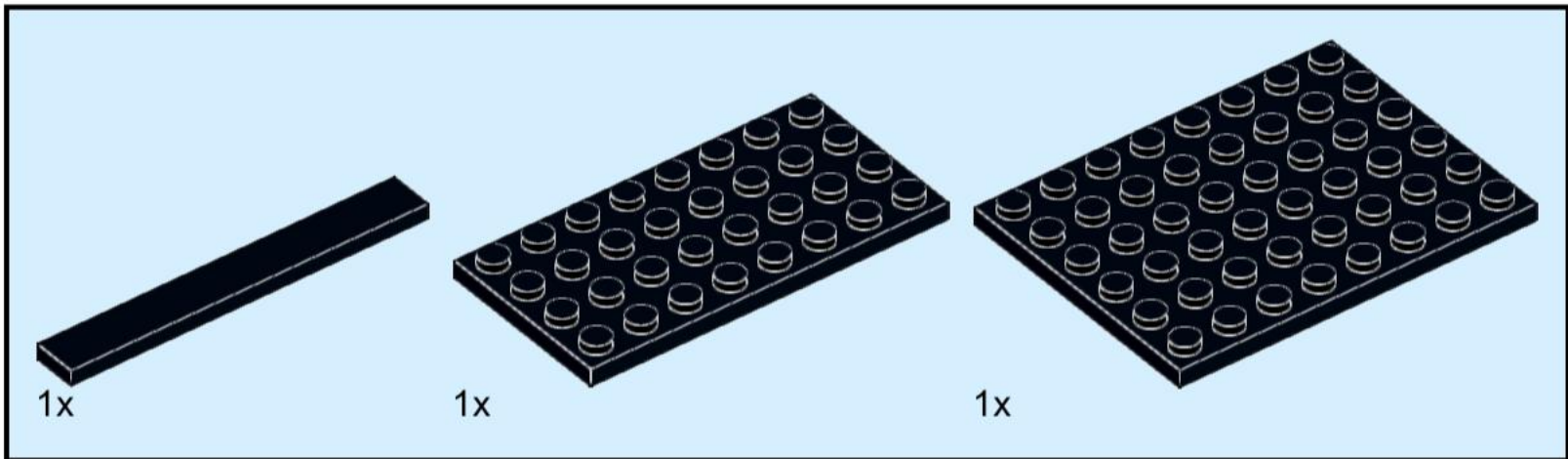

2

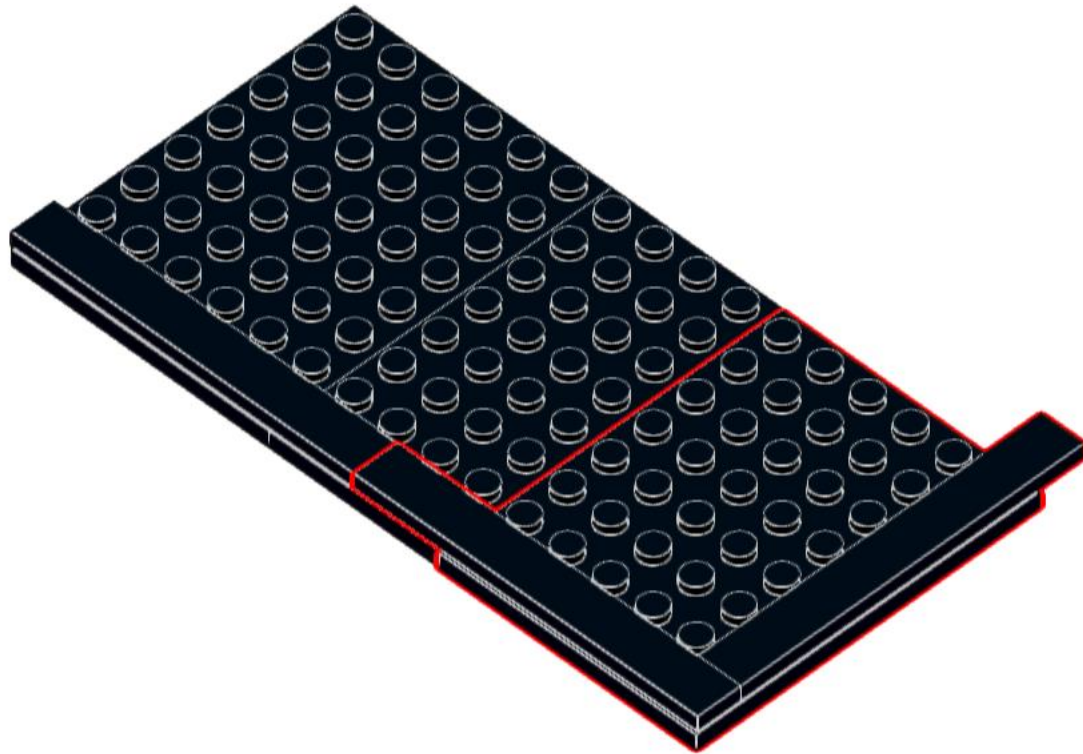
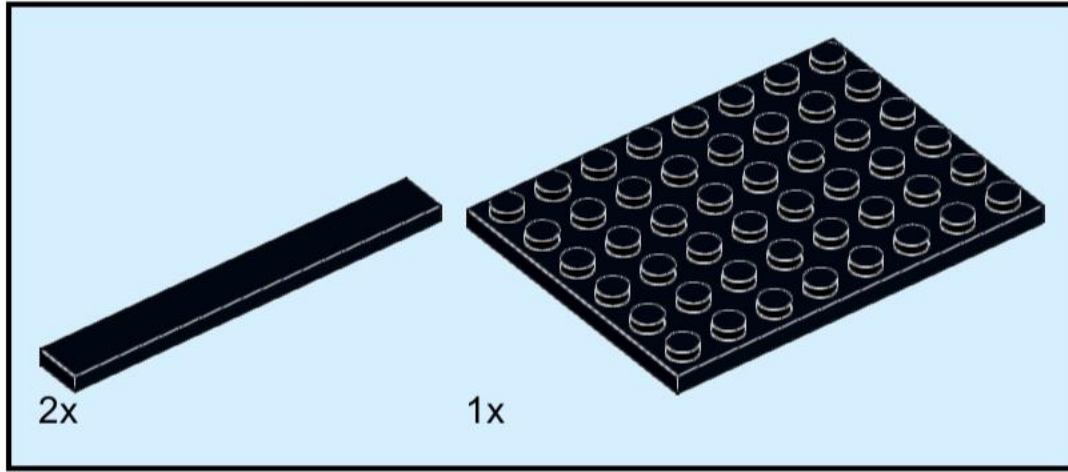

3

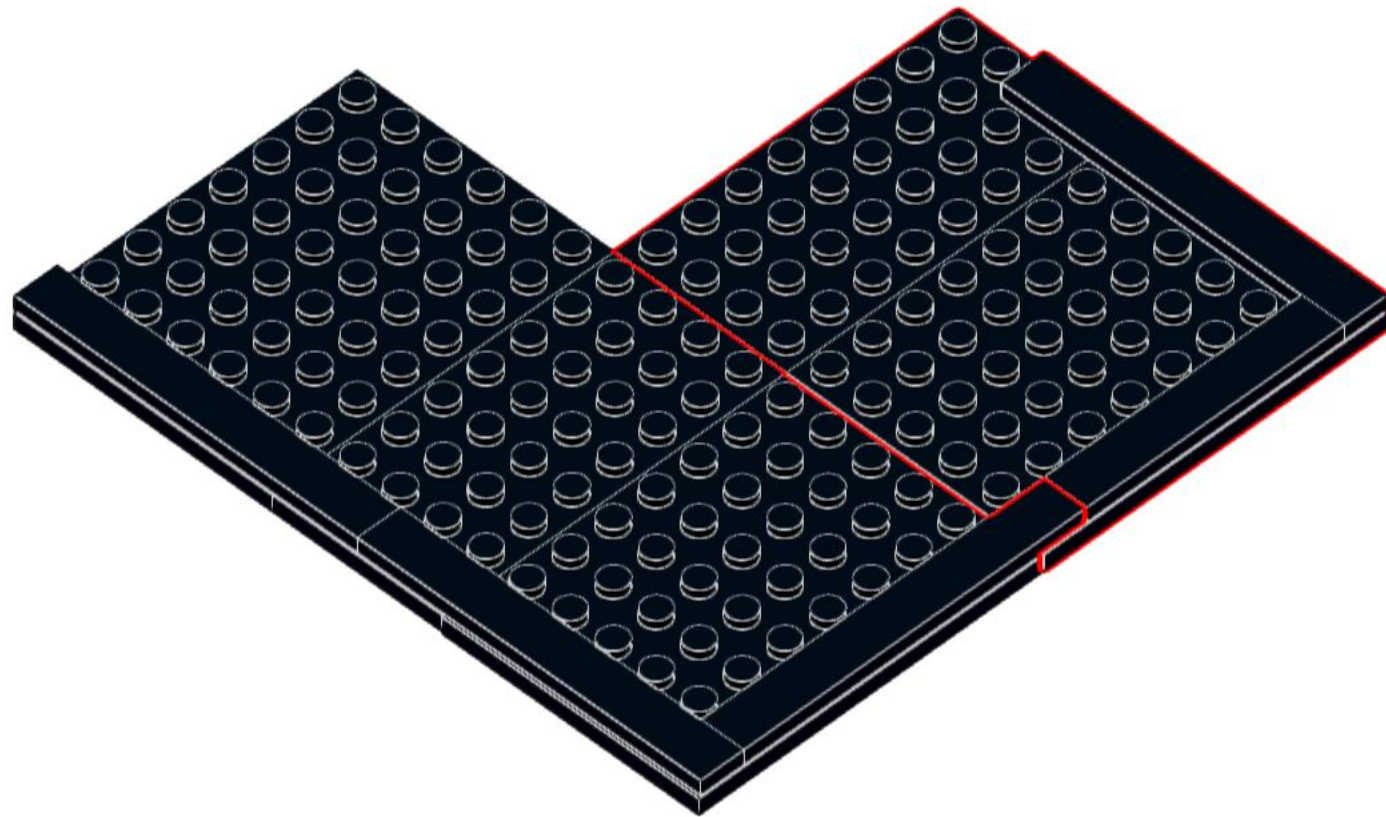
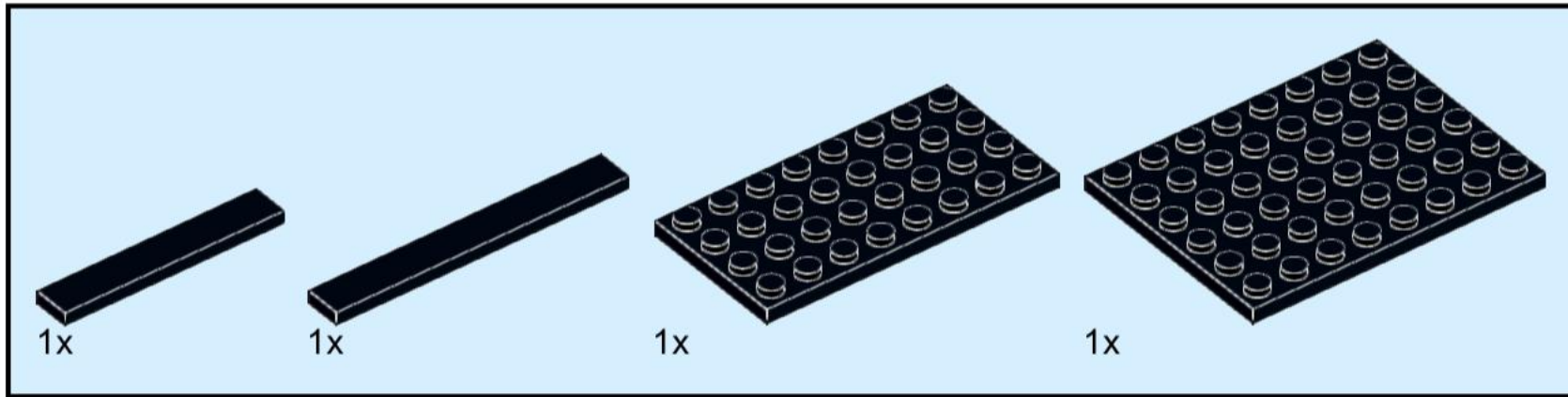

4

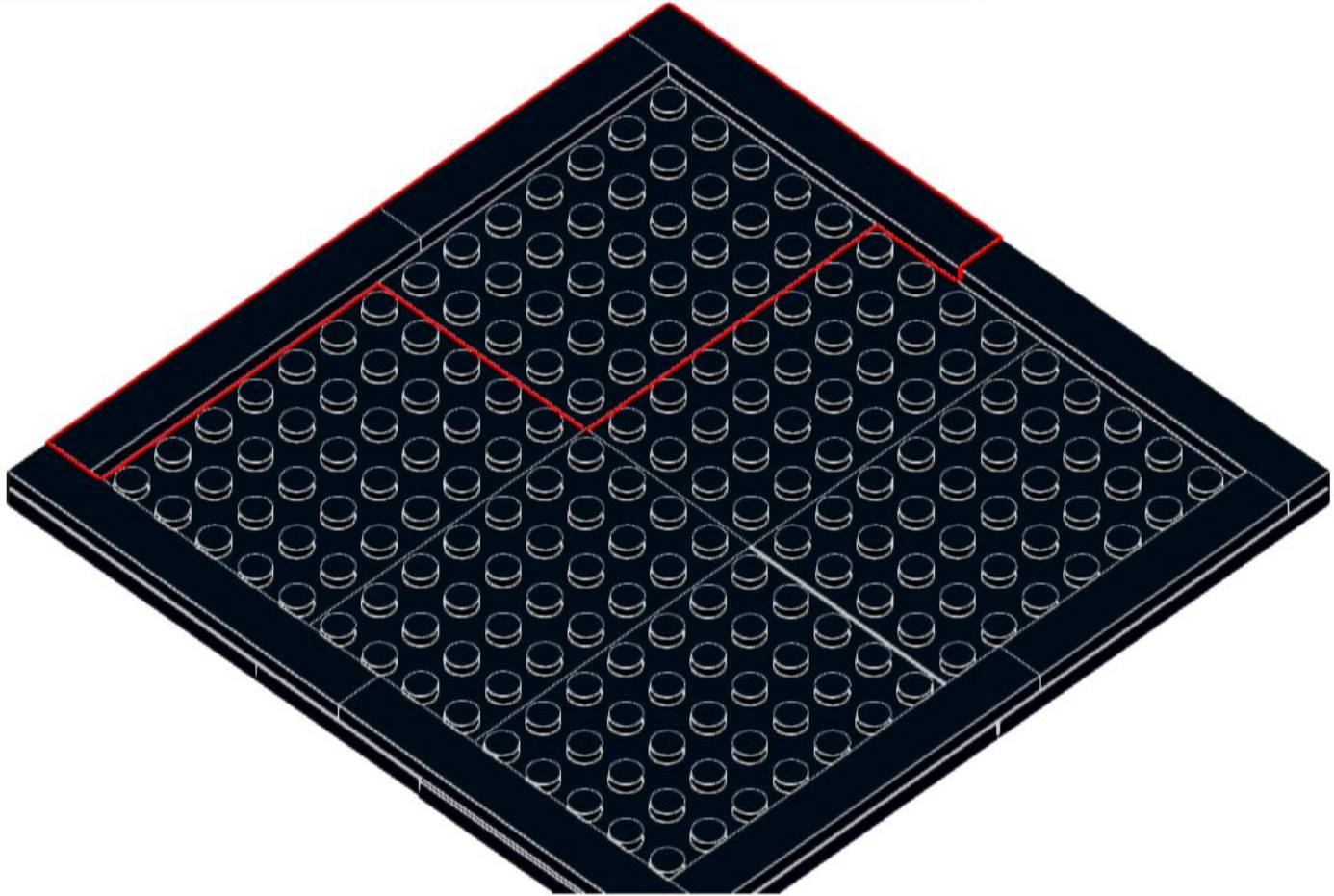
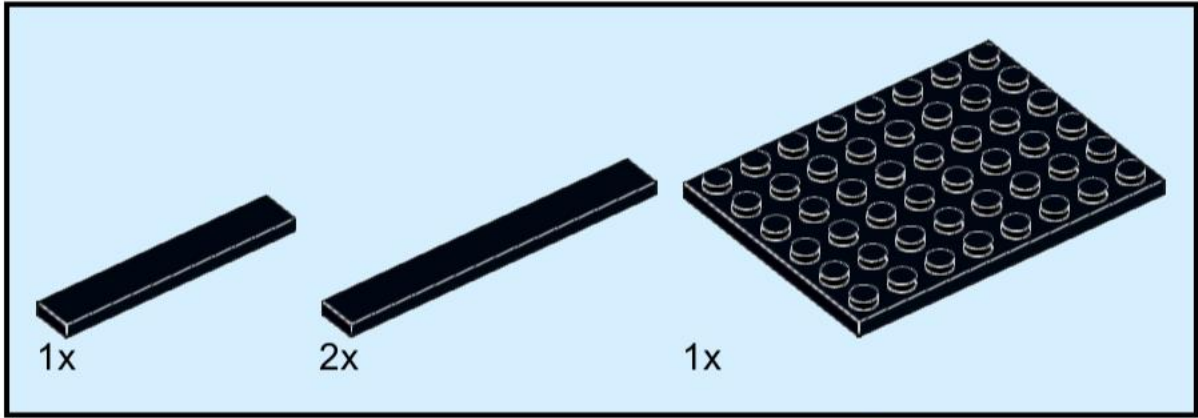

5

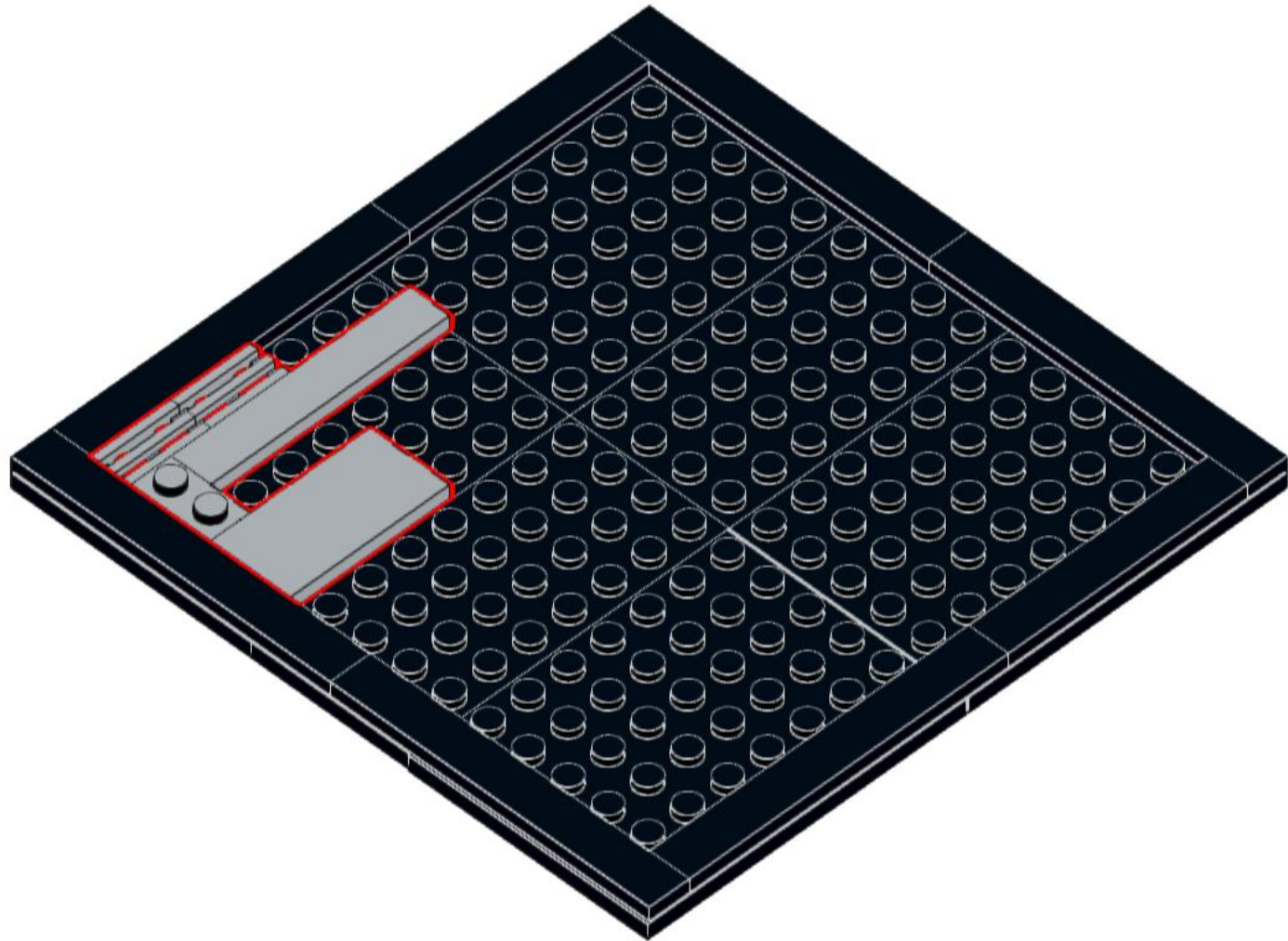
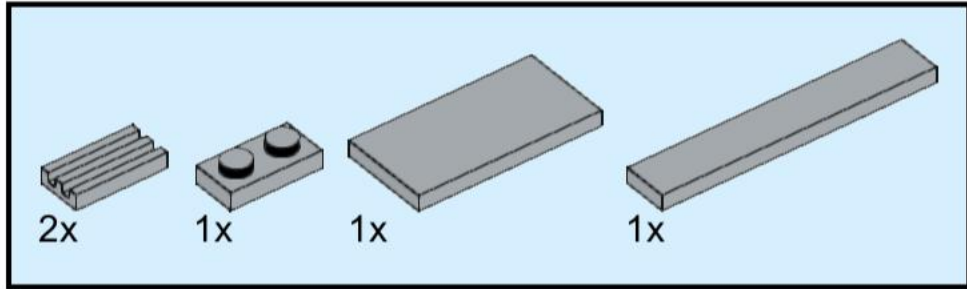

6

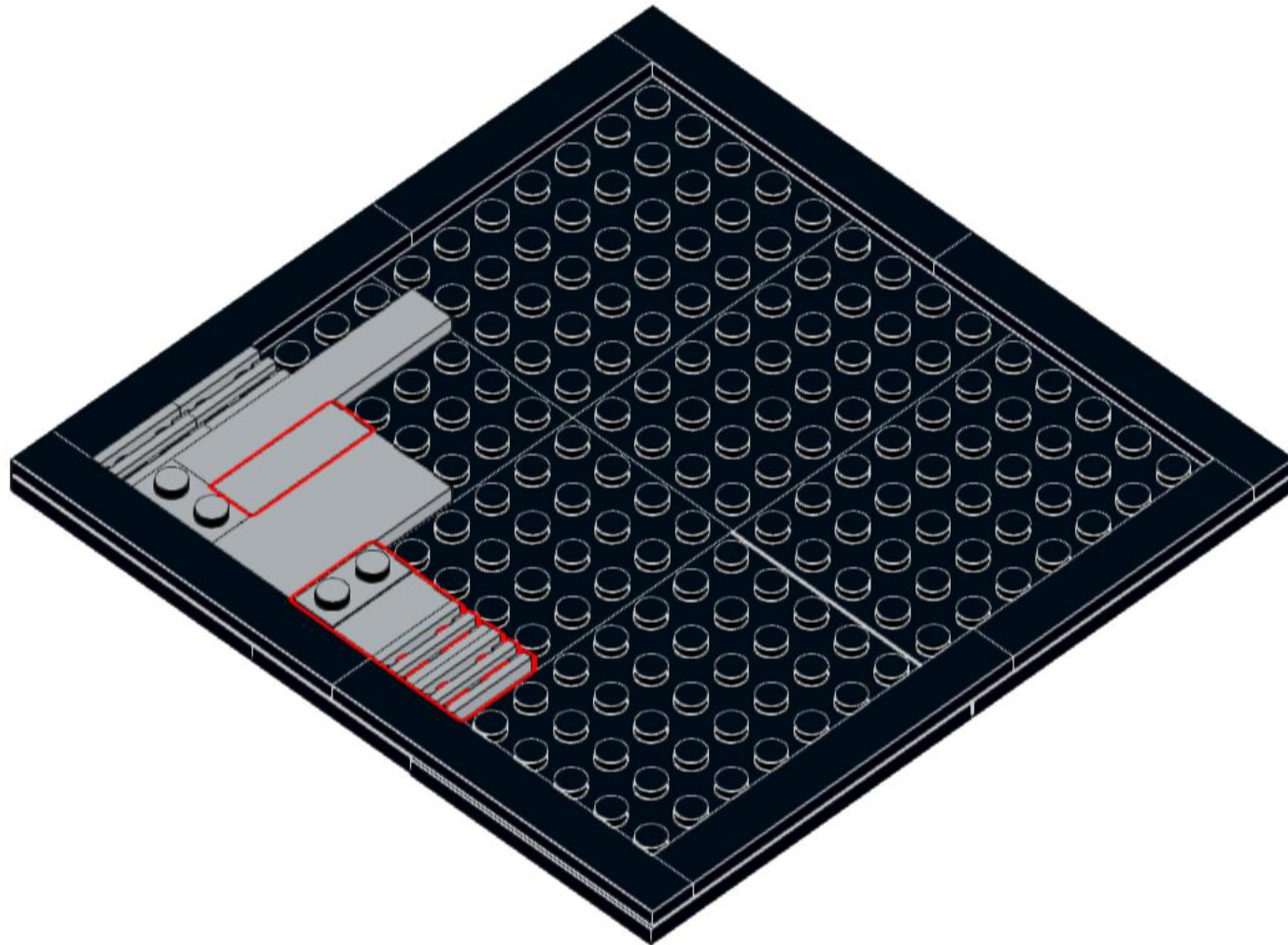
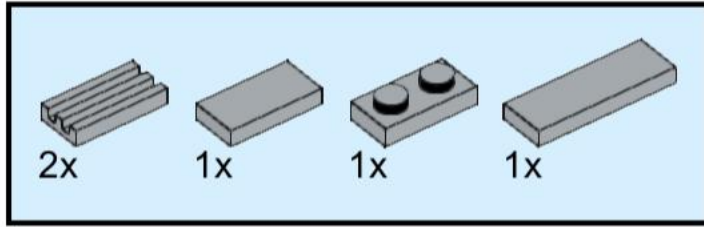

7

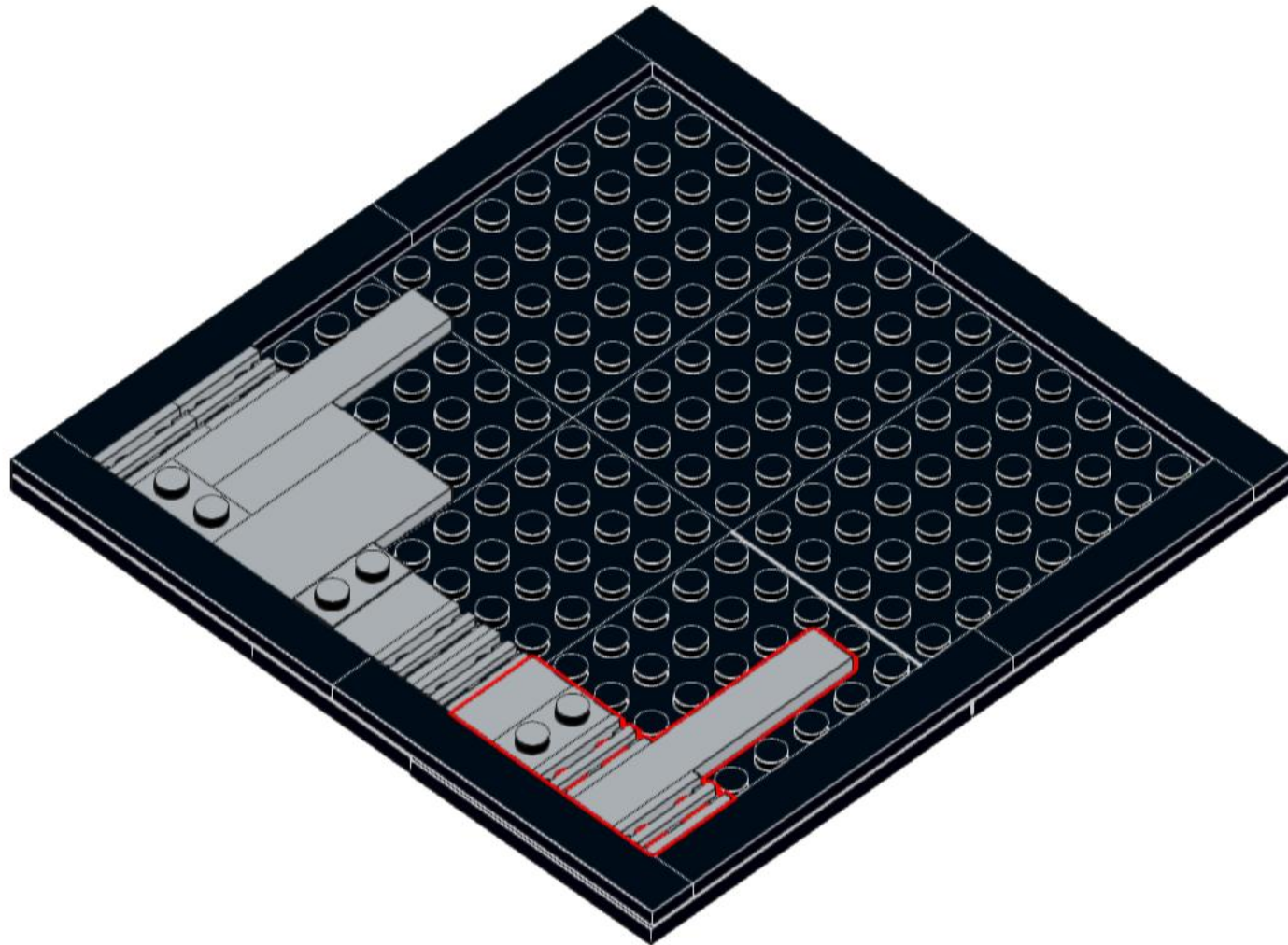
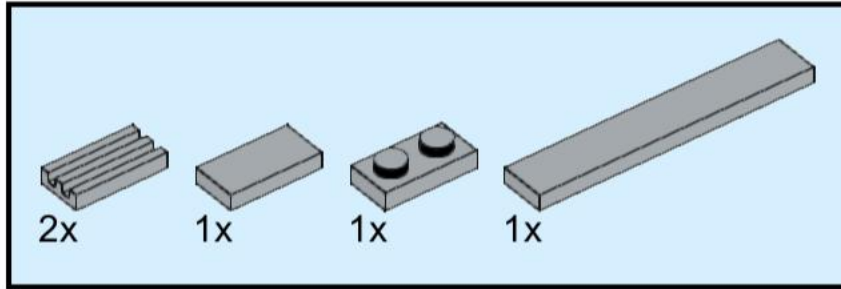

8

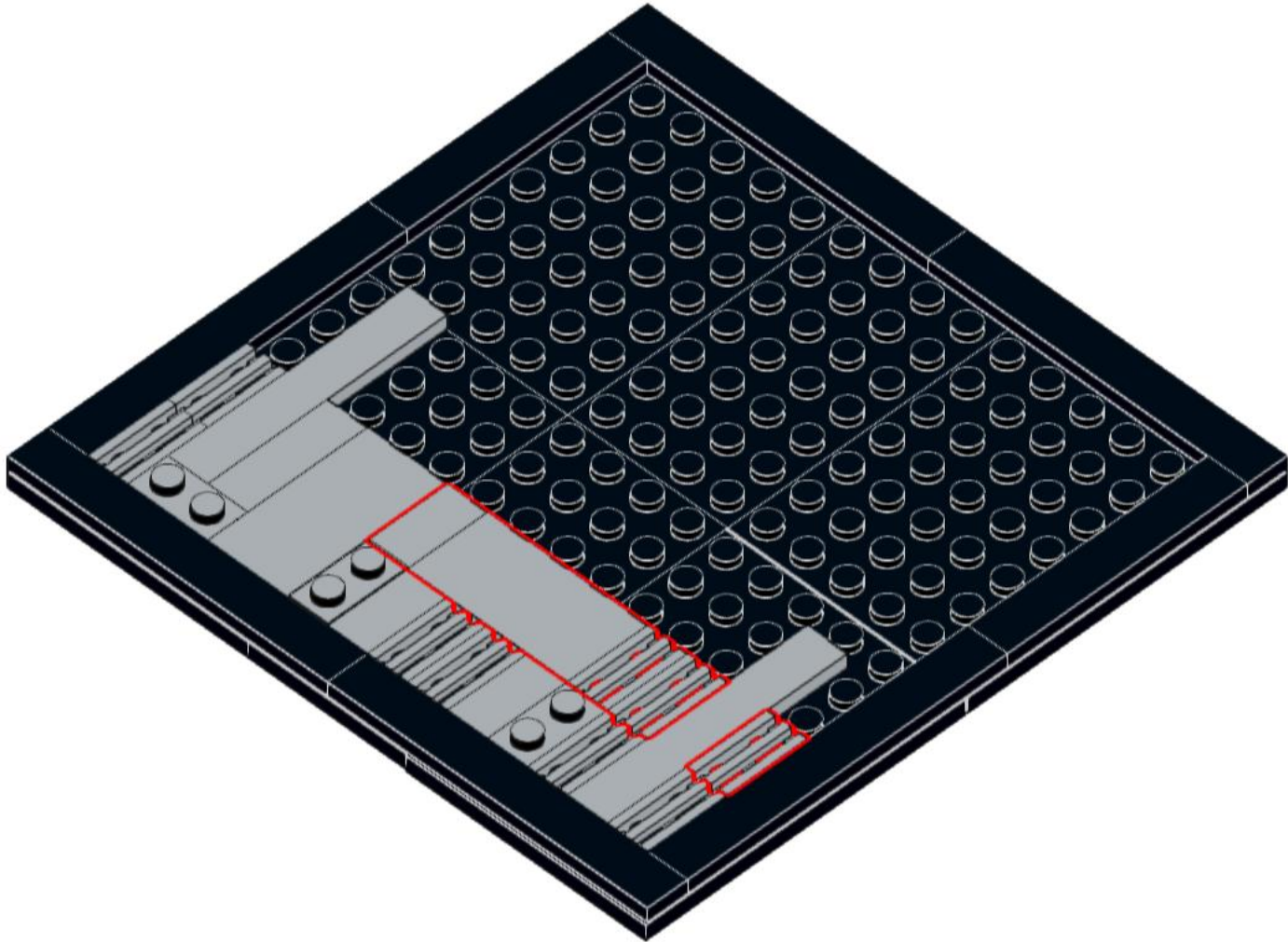
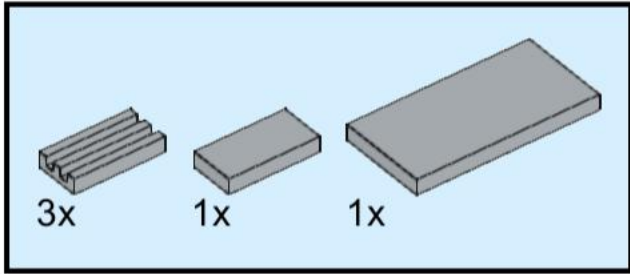

9

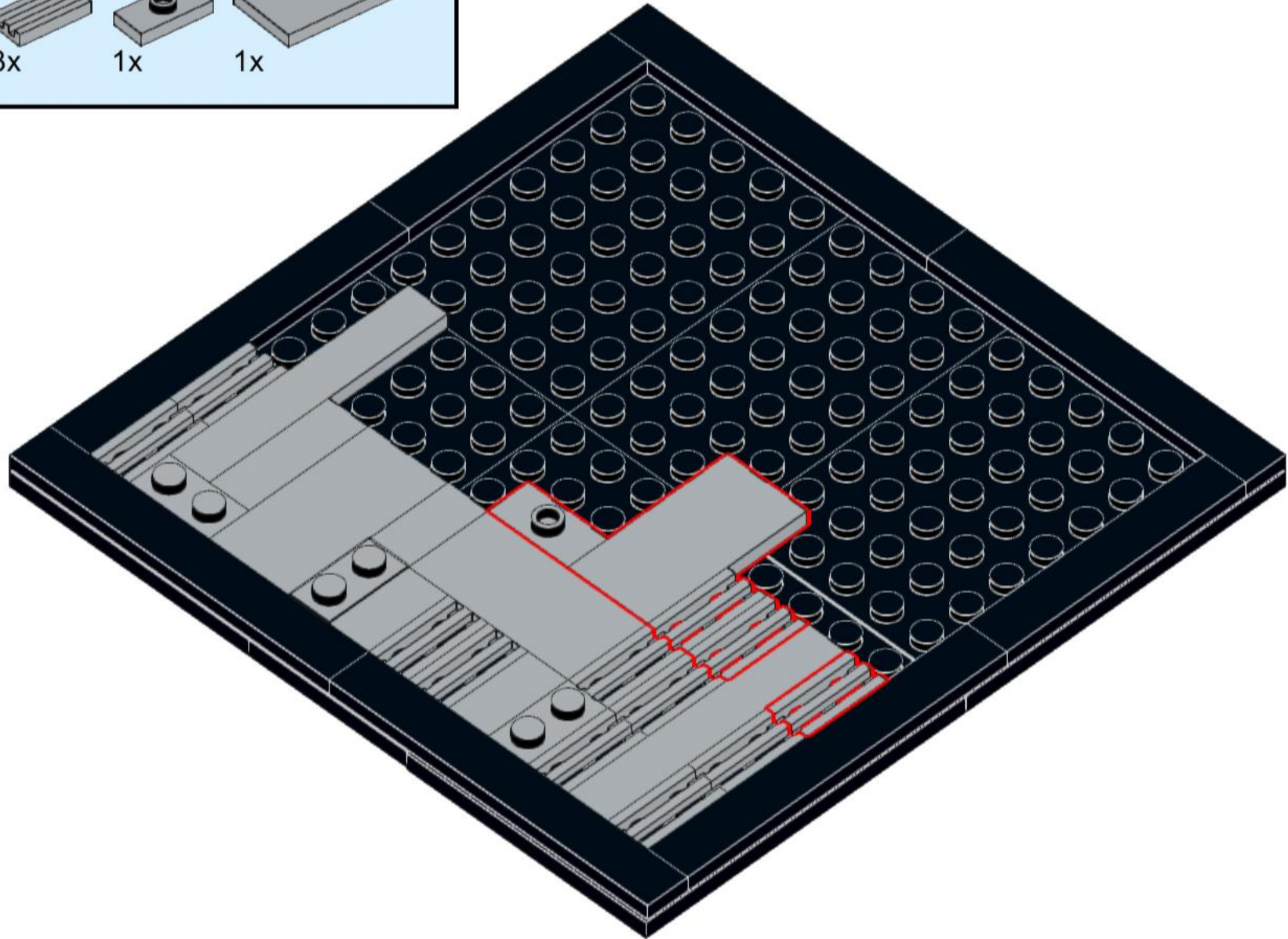
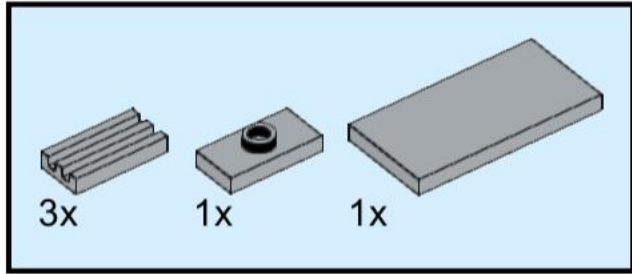

10

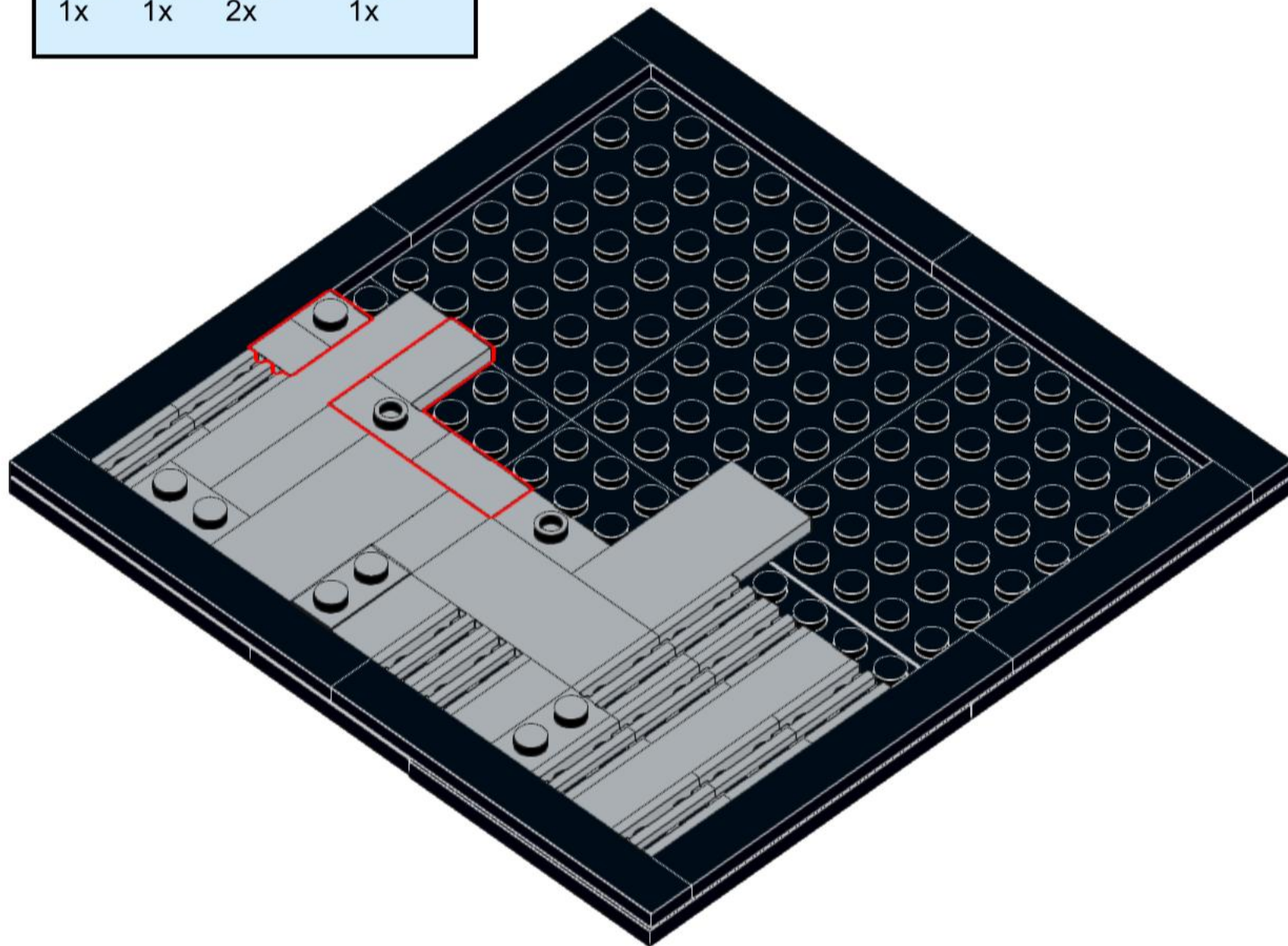
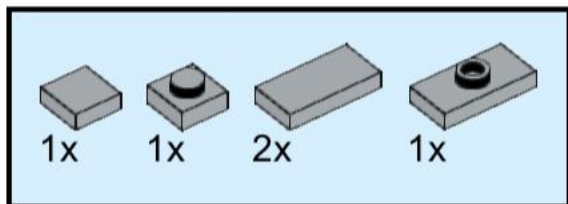

11

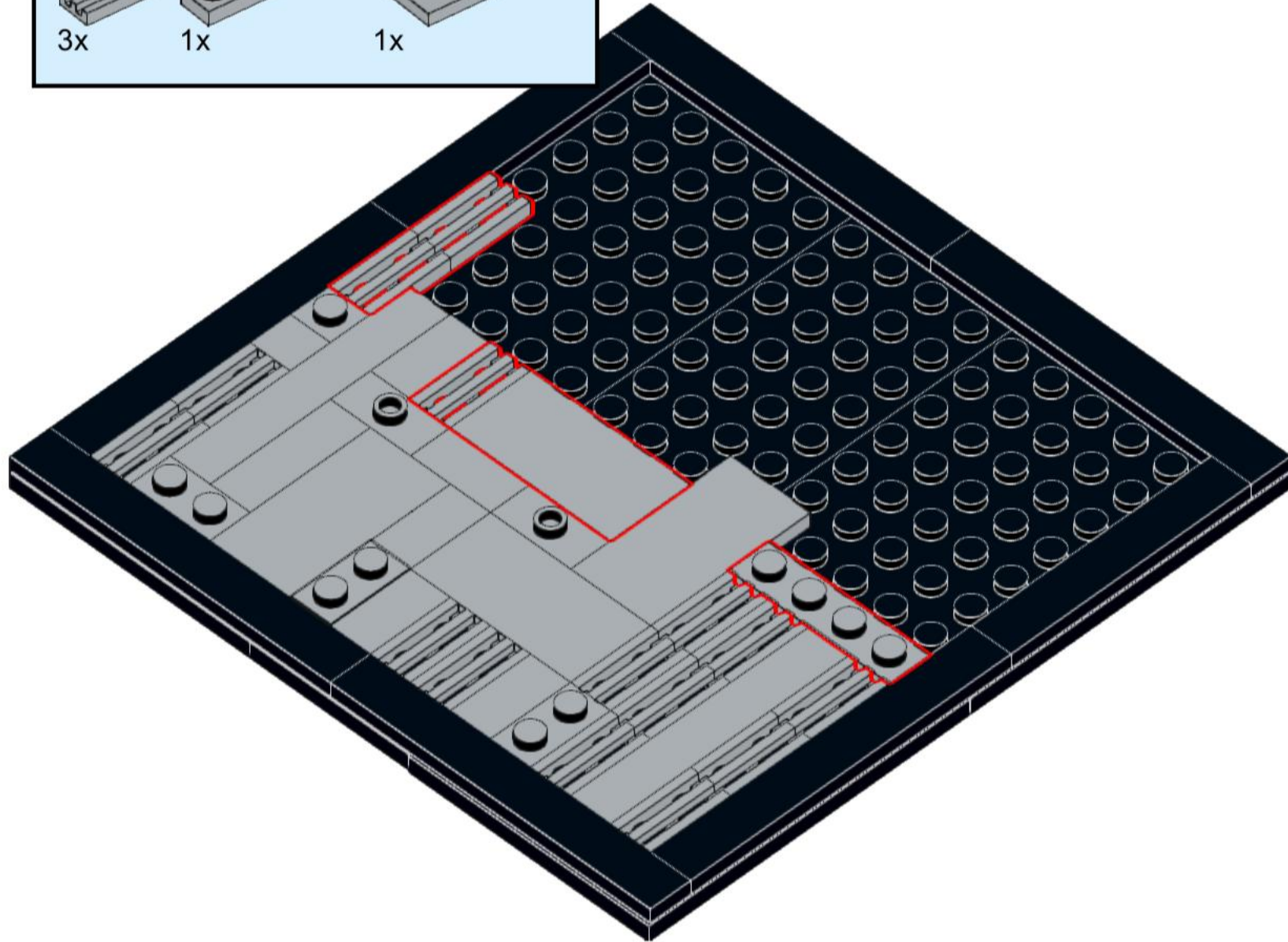
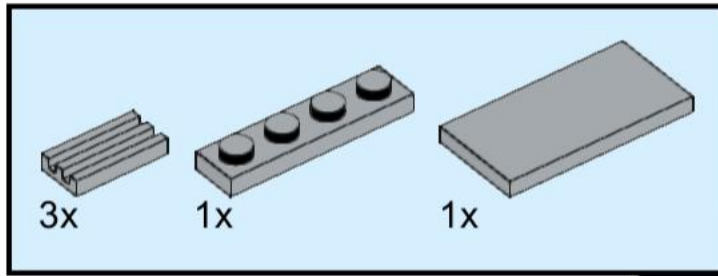

12

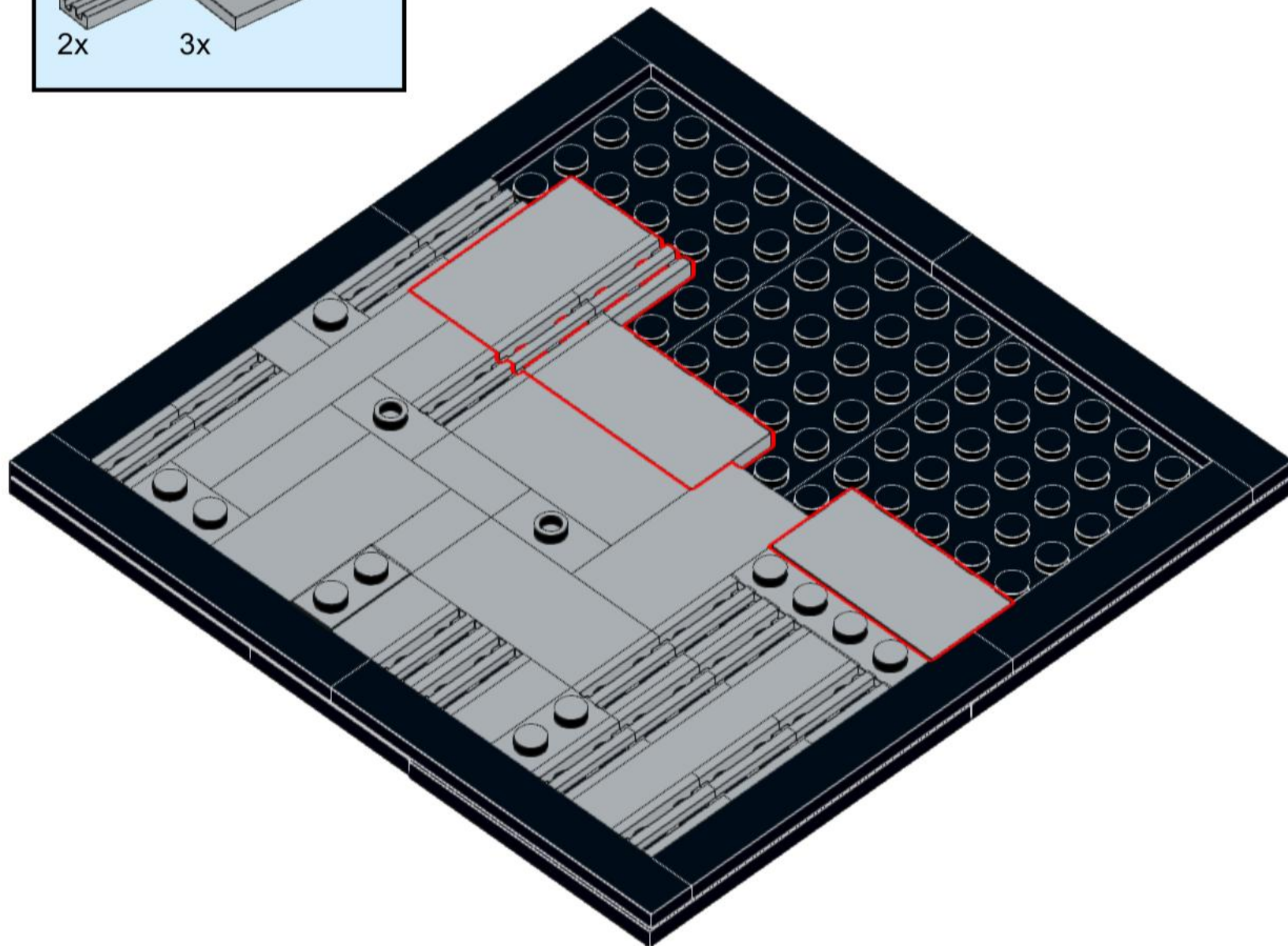
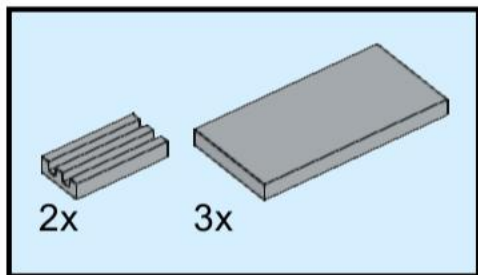

13

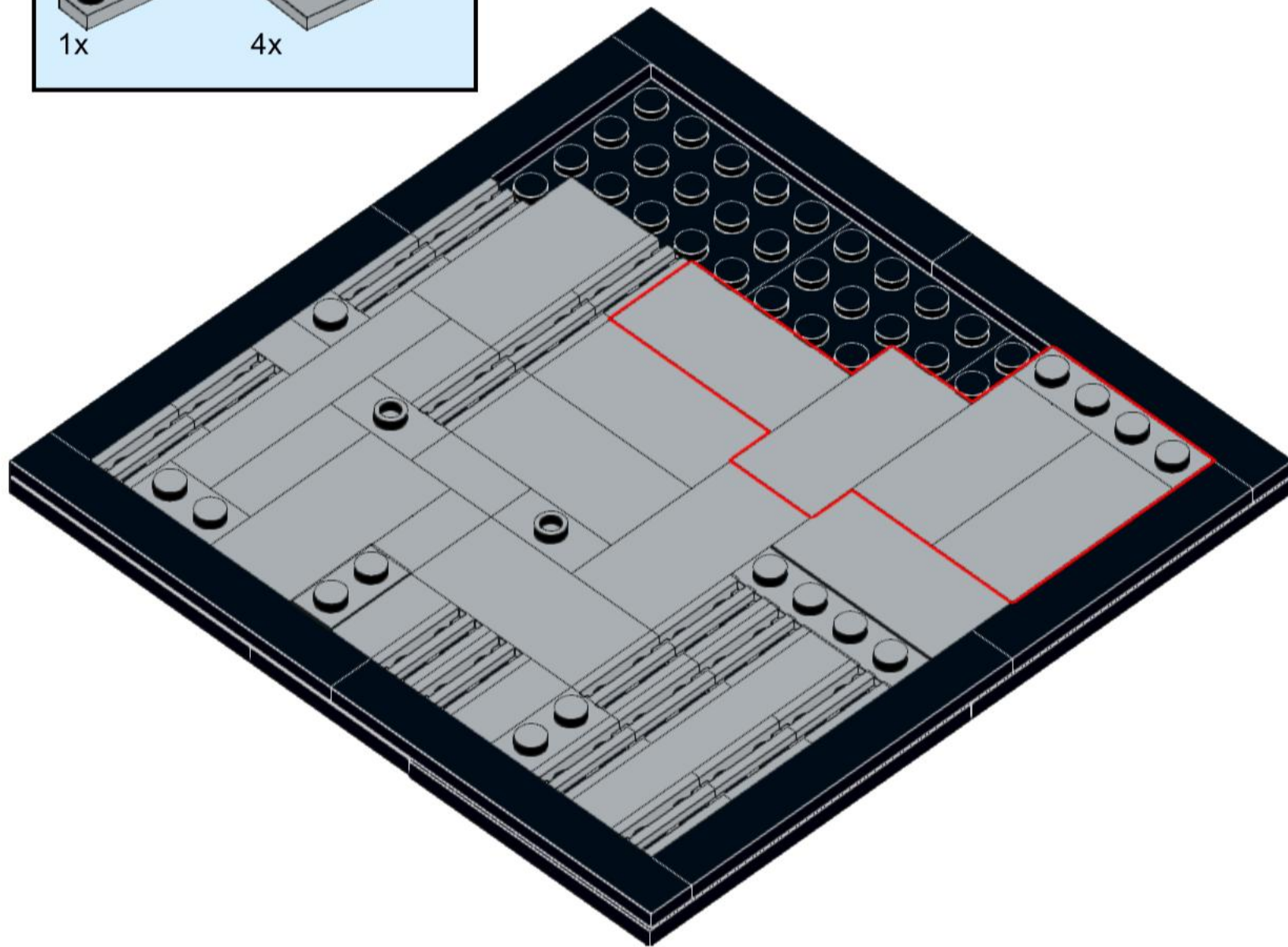
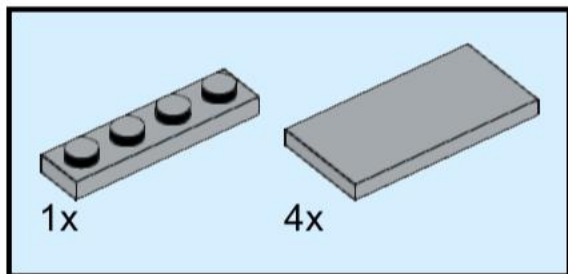

14

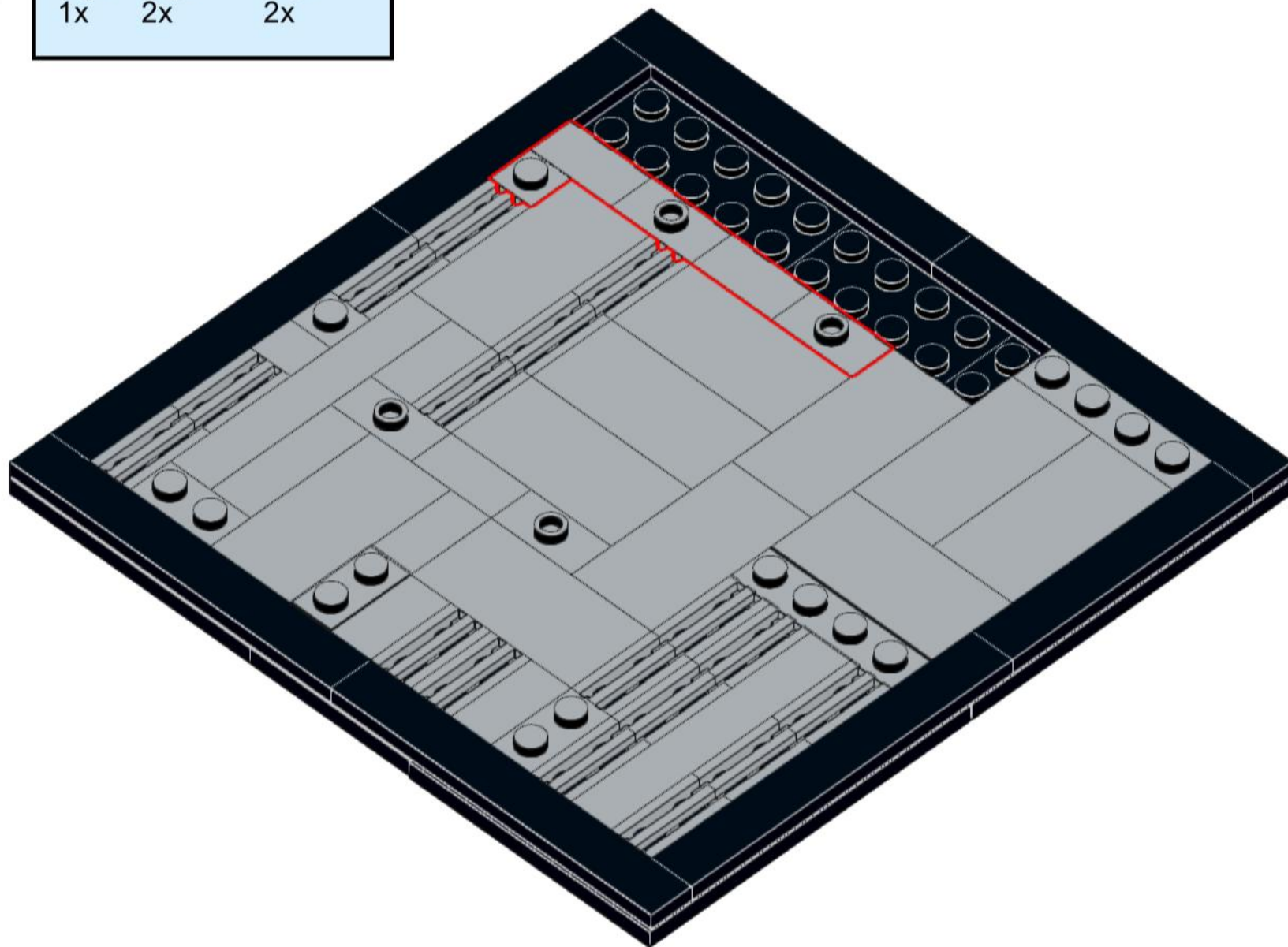
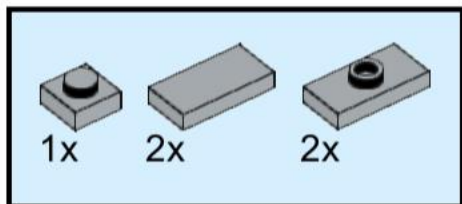

15

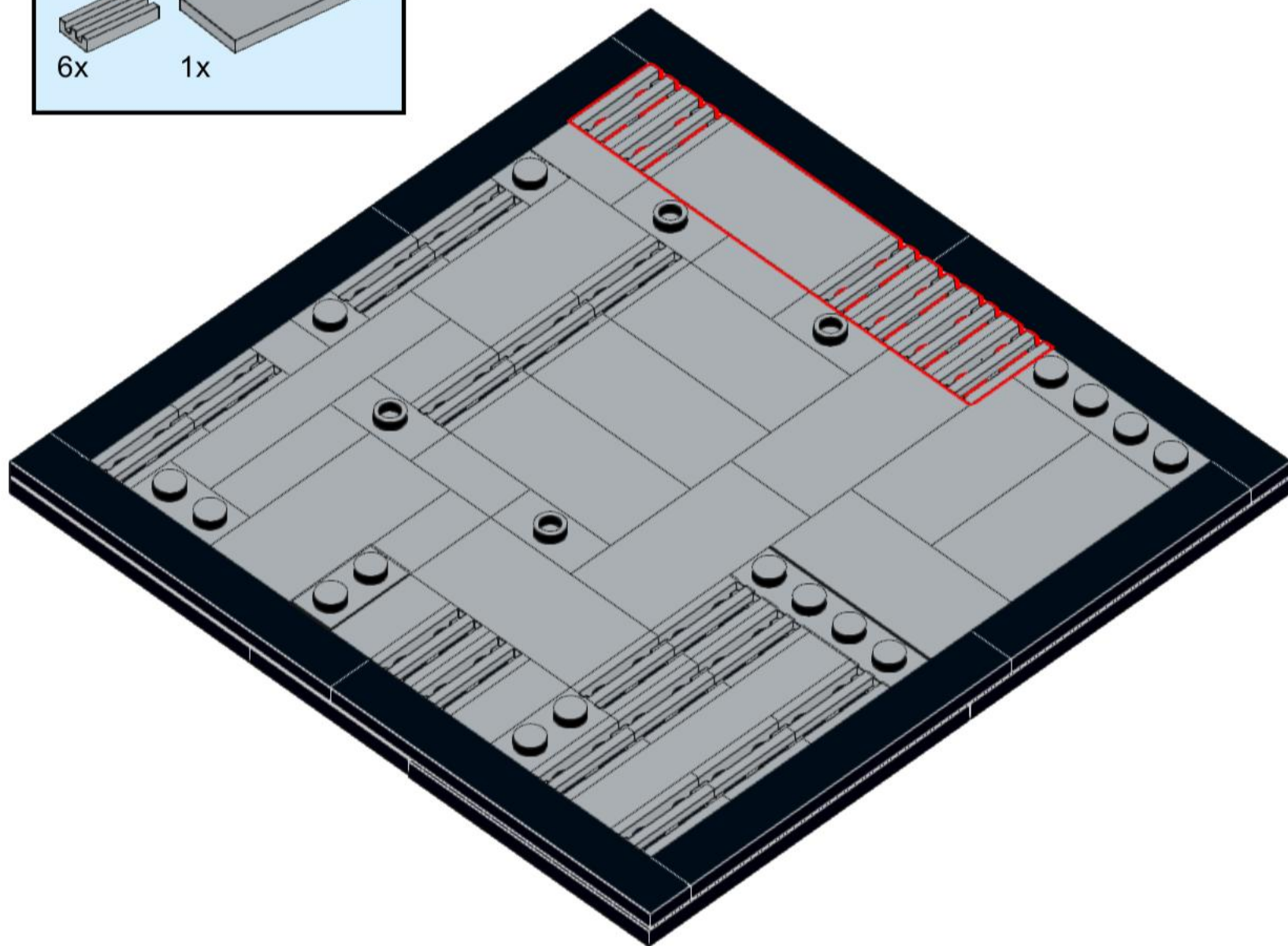
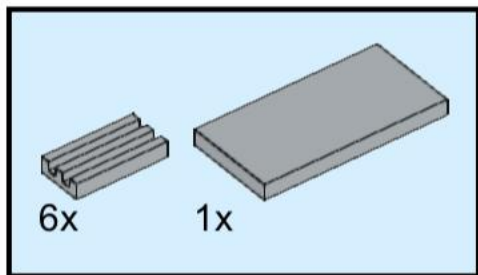

16

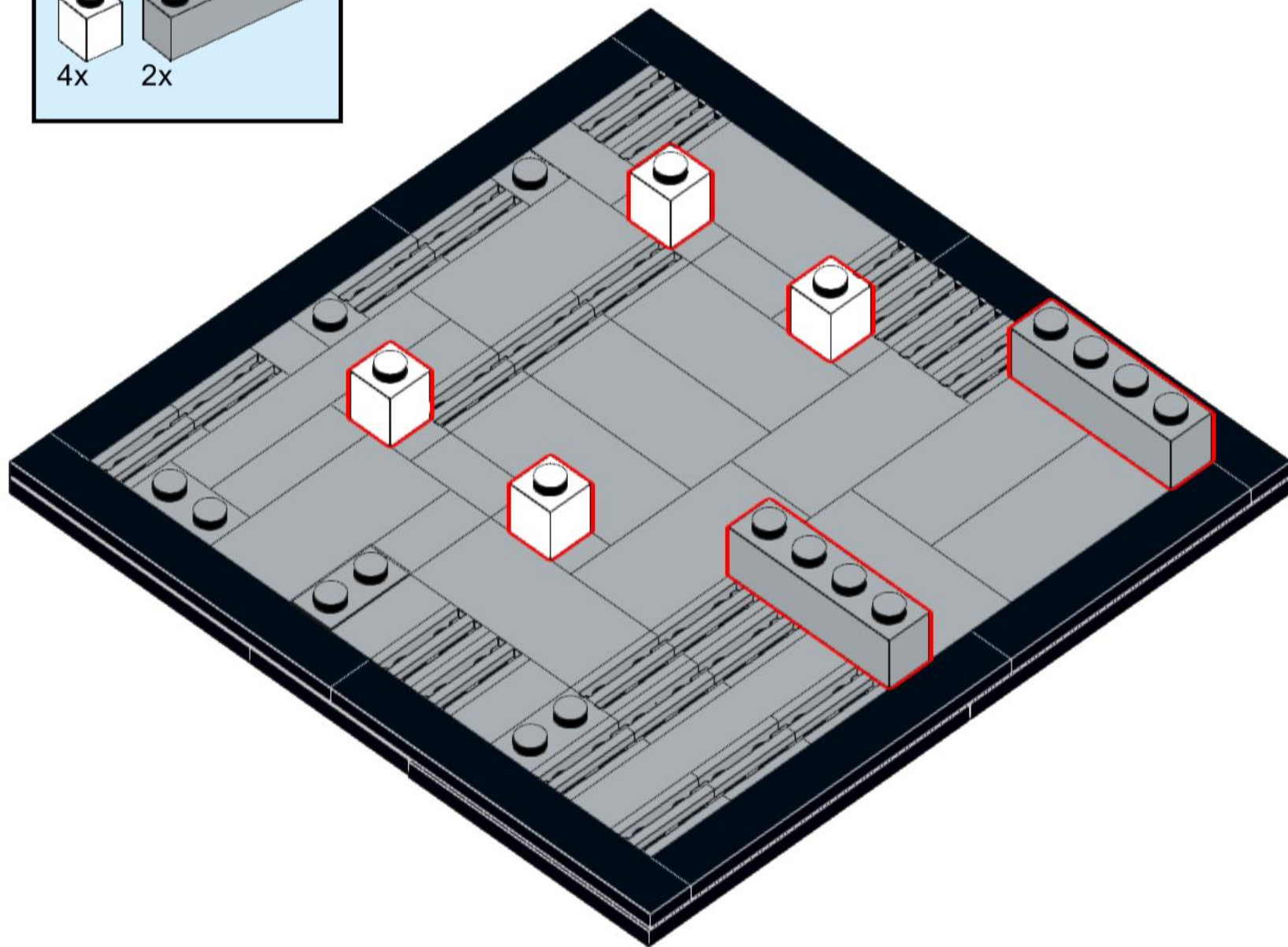
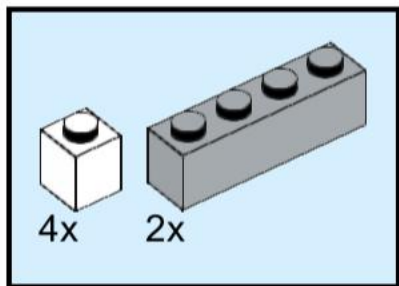

17

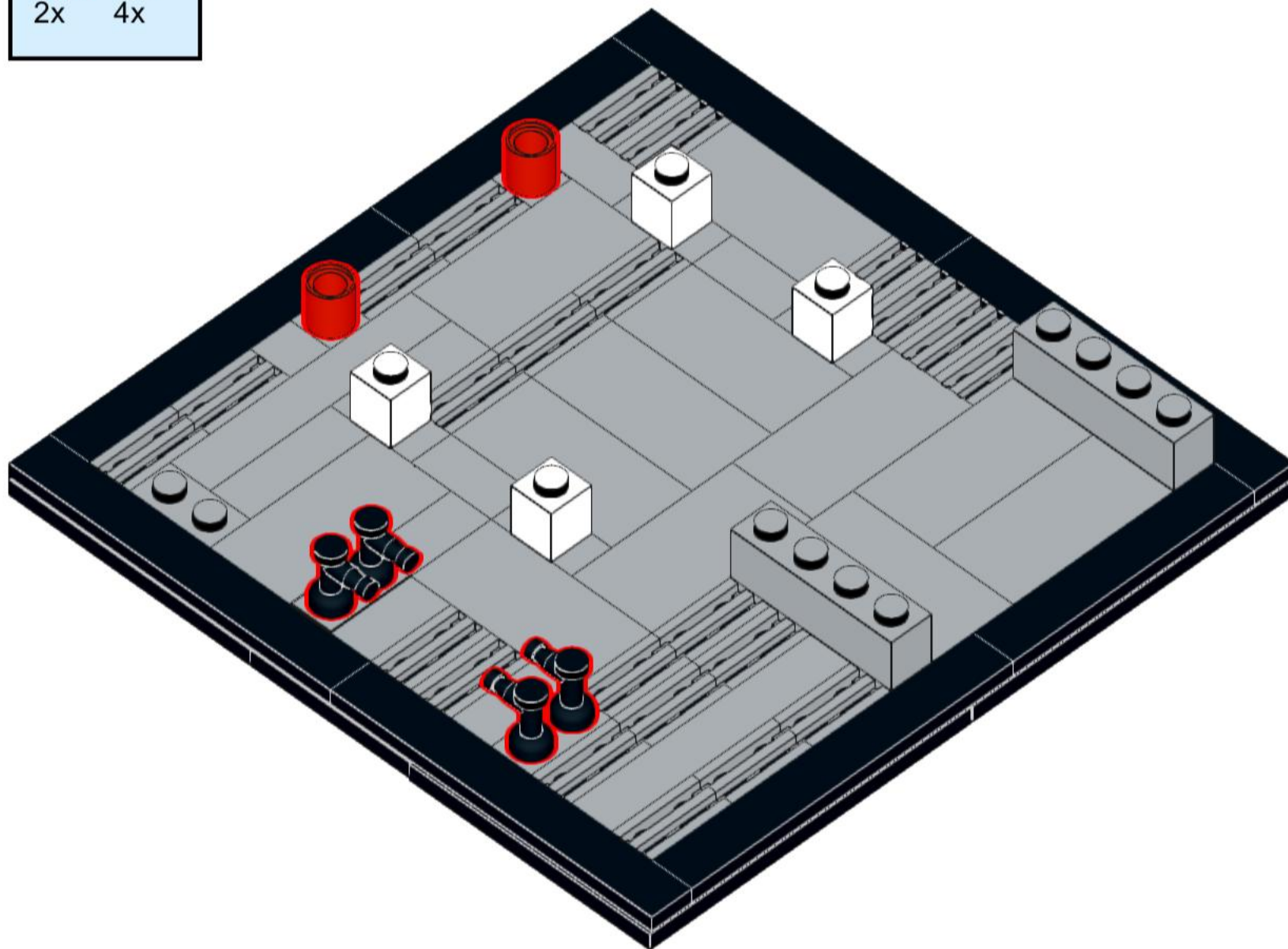

18

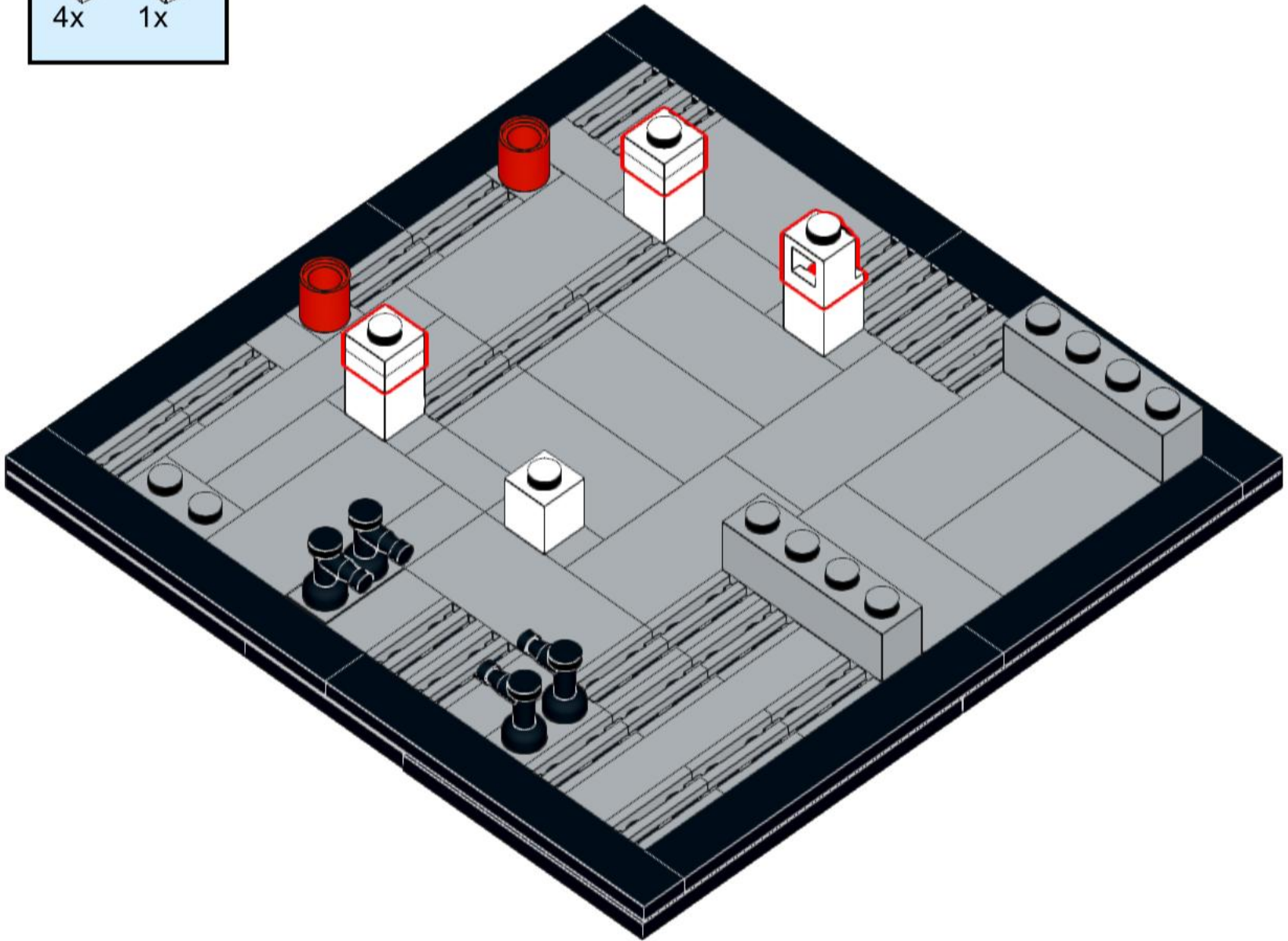
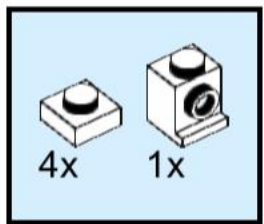

The Compressor

The Compressor is the heart of the refrigeration cycle. It compresses the Refrigerant increasing its pressure and heat. The Compressor then pumps the heated and high pressure gas to the condenser. Its purpose is to heat the gas so that it can be condensed into a liquid (change of state) in the Condenser.

There are many different types of compressor but this system uses the basic mechanism of a piston and cylinder block to create a pumping action. Boyle's Law stated that 'as the volume decreases, pressure increases.' As the pistons move up within the cylinder they decrease the volume in the cylinders causing an increase the pressure, which heats the Refrigerant.

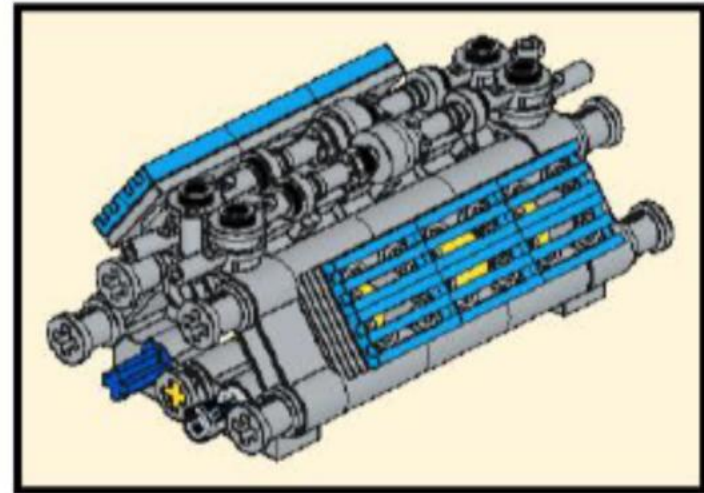

There are different types of compressors and more information can be found at:
<https://www.fantasticfridges.com/AdvancedTopics/InsideARefrigerationSystem>

19

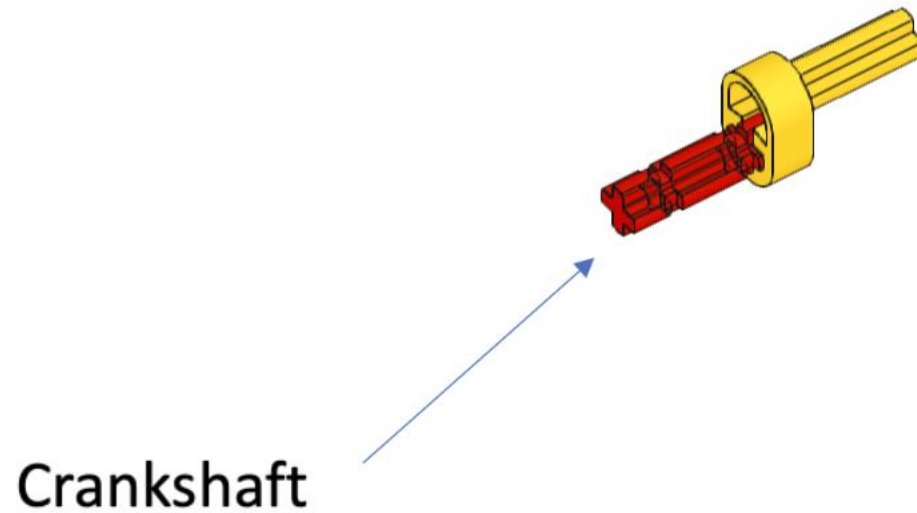
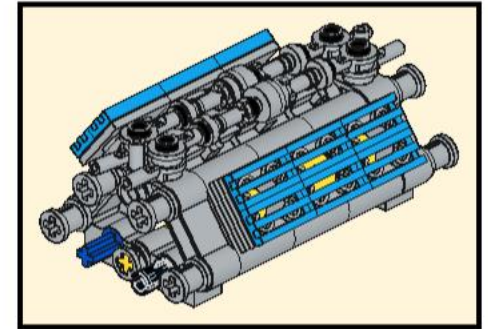
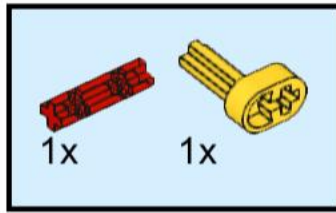

Making the Compressor – The Pistons

The Pistons move up and down increasing the pressure of the gas

20

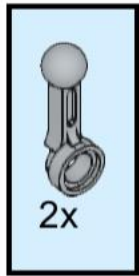

Connecting Rods

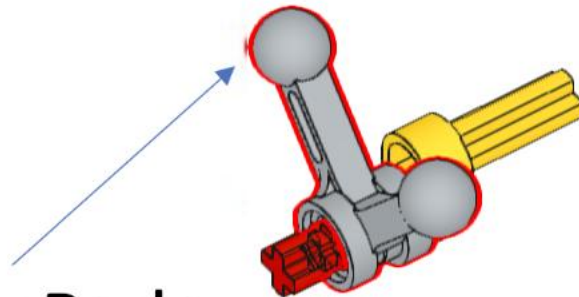

21

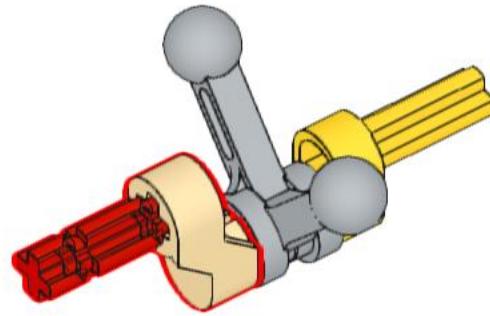
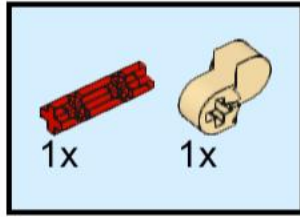

22

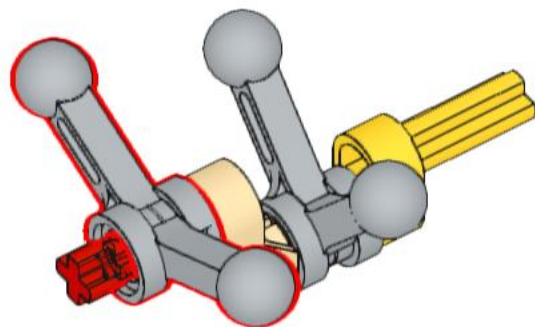
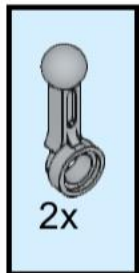

23

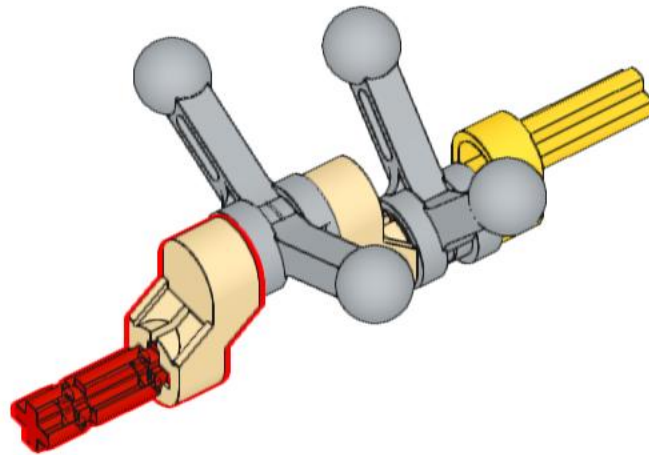
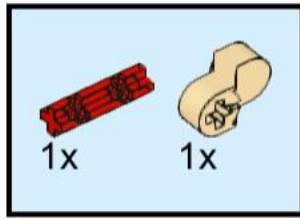

24

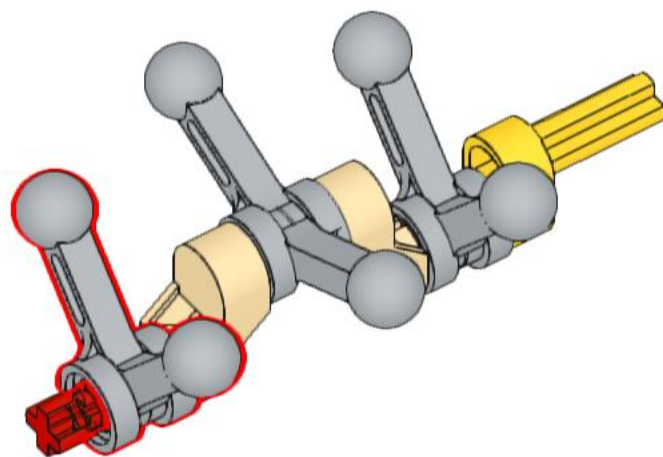
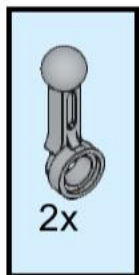

25

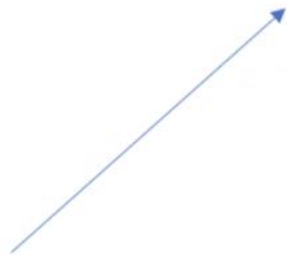
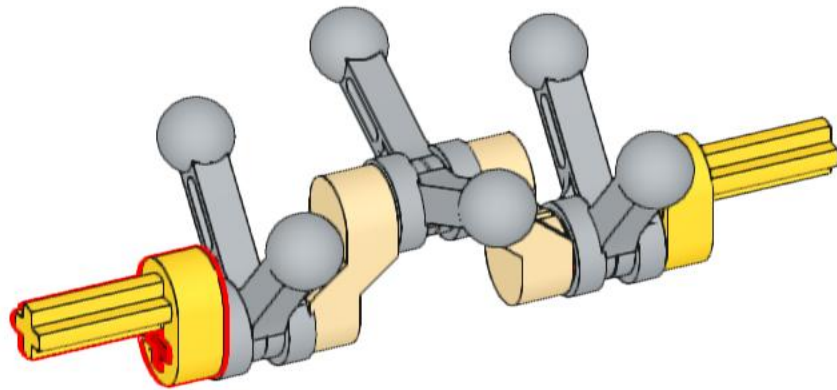
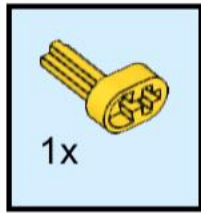

Series of connecting rods and crankshafts

26

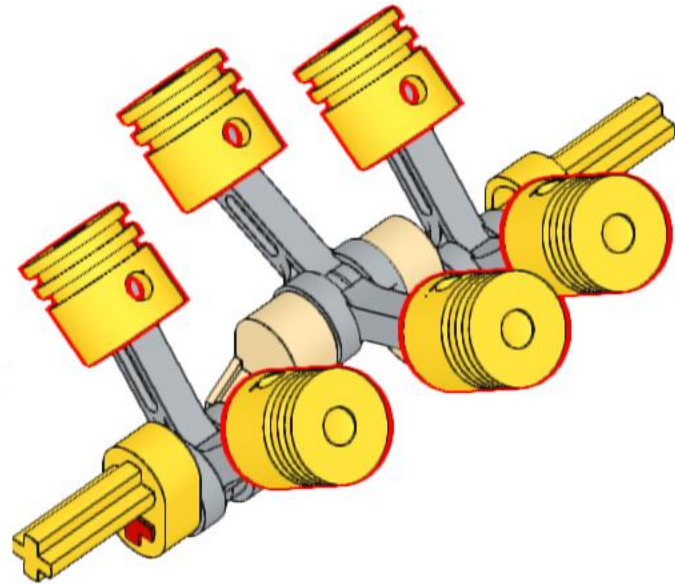
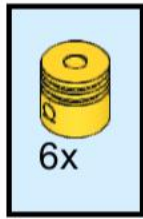

Adding the pistons

27

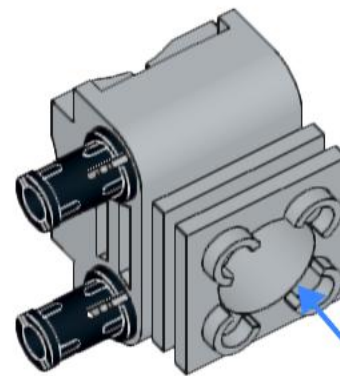
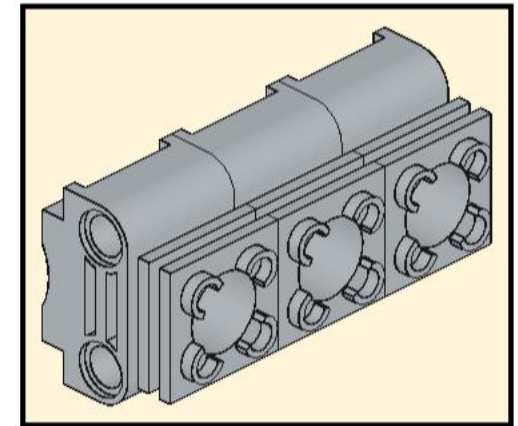
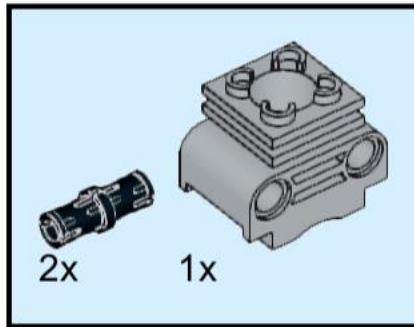

Cylinder

Making the Compressor – The Cylinder Block

The Cylinder Block holds the Pistons.

28

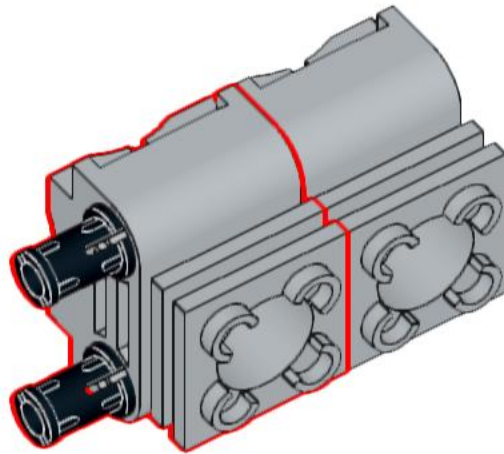
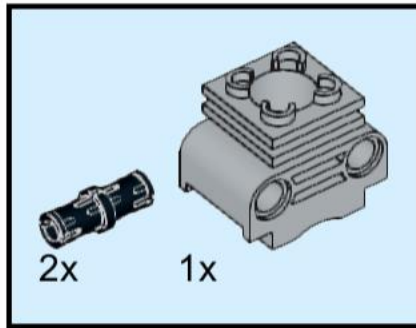

29

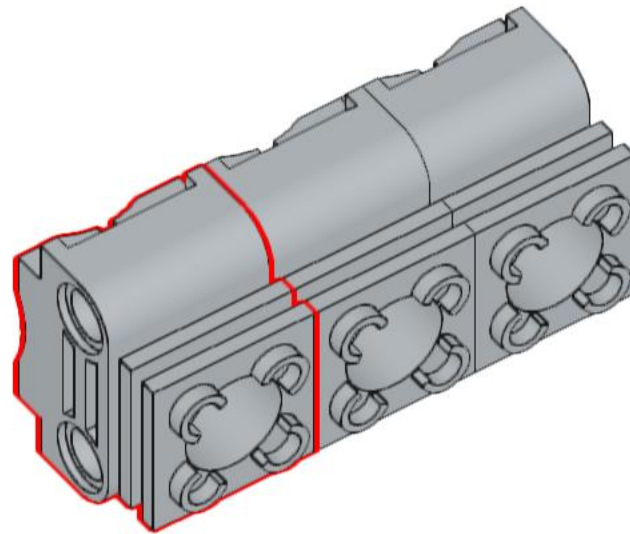
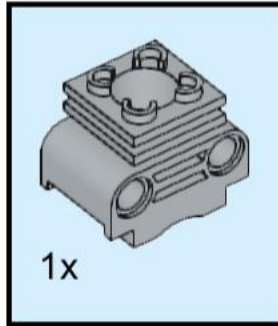

Making the Compressor – The Cylinder Block

The Cylinder Block holds the series of pistons in place while they move up and down within the cylinders.

30

Pistons move up and down in the cylinder creating pressure

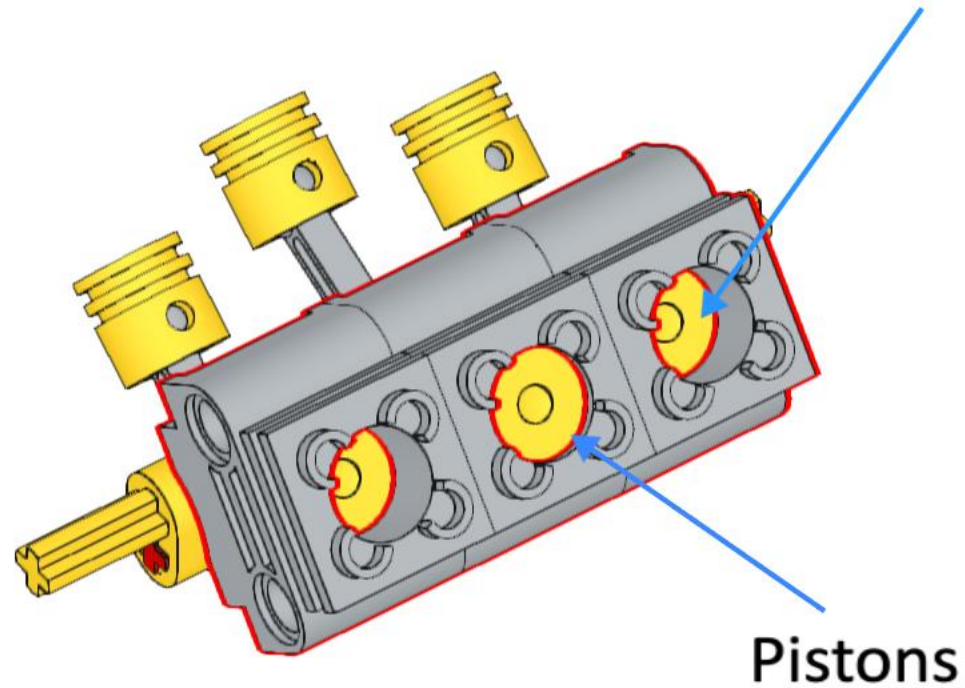

Making the Compressor – The Cylinder Block

Adding the pistons to the cylinder block.

31

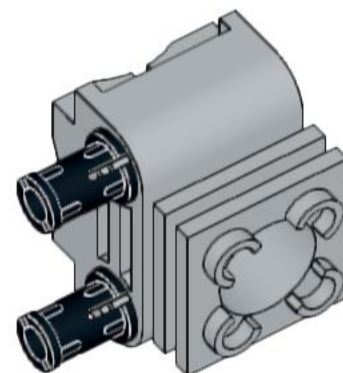
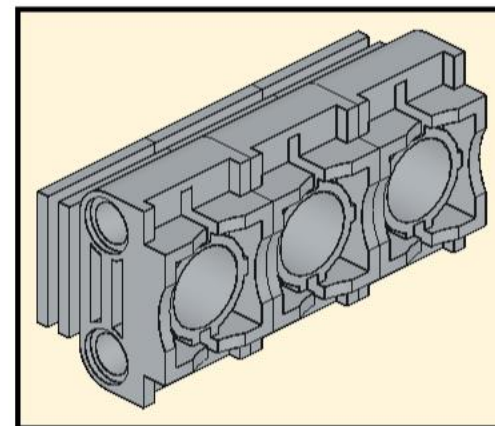
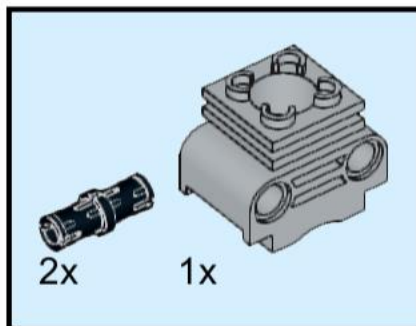

32

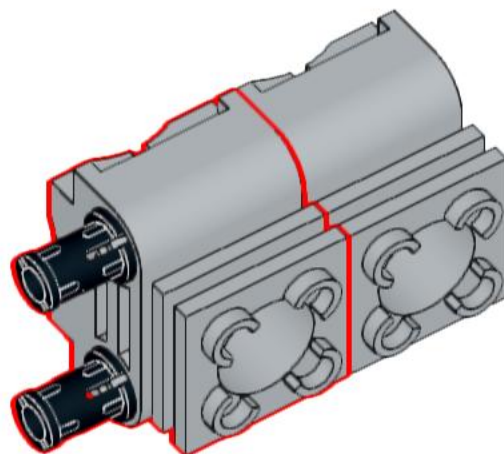
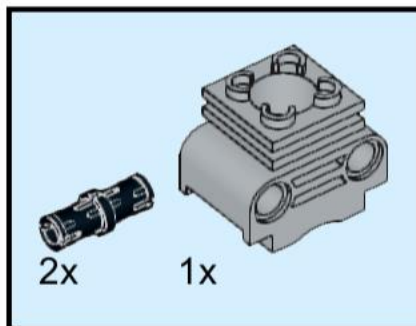

33

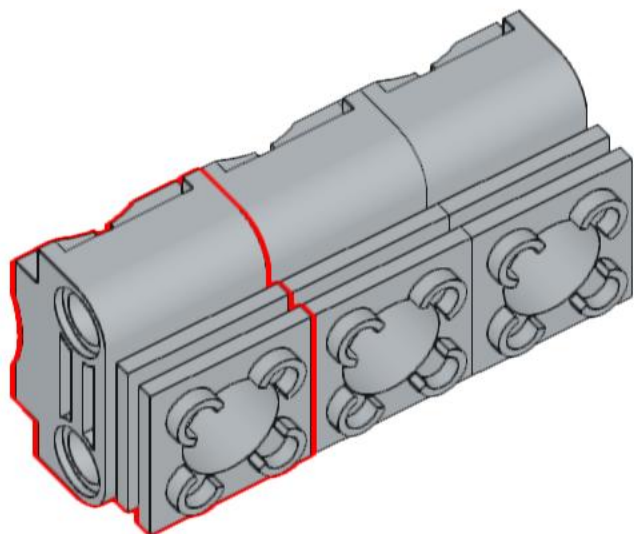
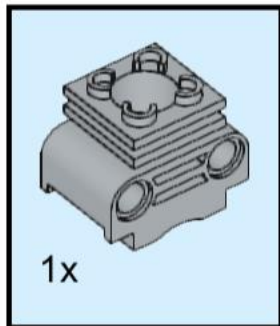

34

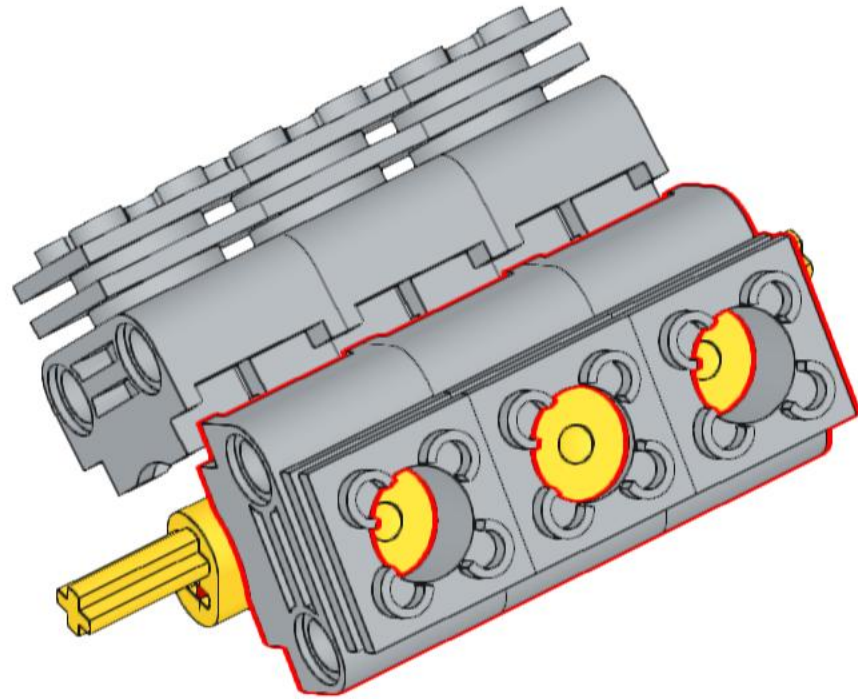

How the pistons in a compressor work

Boyle's Law stated that 'as the volume decreases, pressure increases.' As the pistons move up within the cylinder they decrease the volume in the cylinders causing an increase the pressure, which heats the Refrigerant.

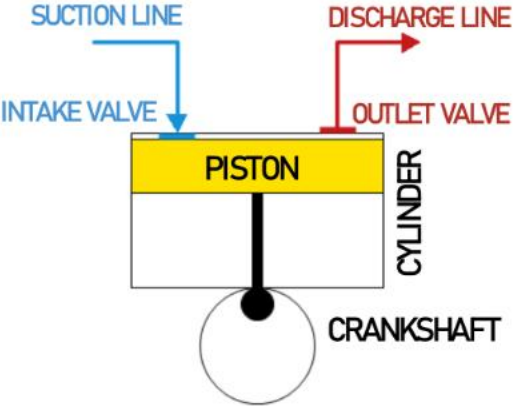

In this position both valves are closed and there is no movement of gas and there is no available space (volume) in the cylinder.

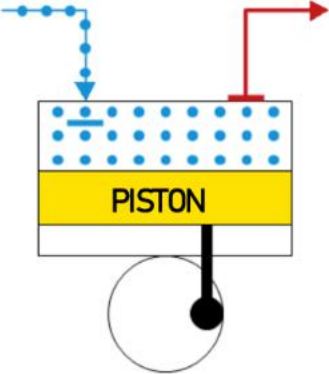

As the piston moves down the intake valve opens and allows the gas to pass into the cylinder from the suction line.

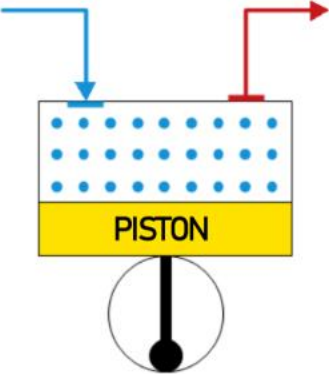

As the piston moves down fully the intake valve shuts. The gas is not under pressure but has filled the available space (volume) in the cylinder. Both valves are closed.

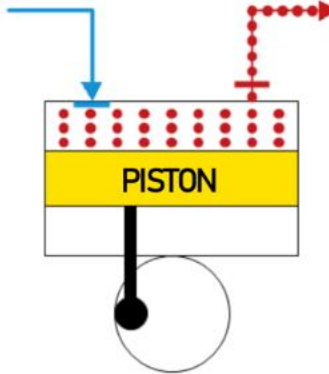

As the piston moves up, it decreases the space (volume) within the cylinder which increases the pressure of the gas. As the pressure increases the temperature also increases. The outlet valve opens and releases the heated and pressurised gas into the discharge line which will take the gas to the condenser.

35

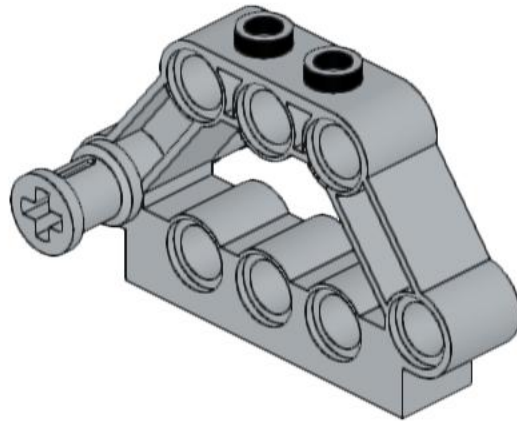
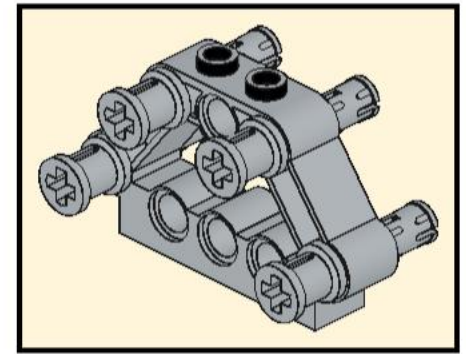
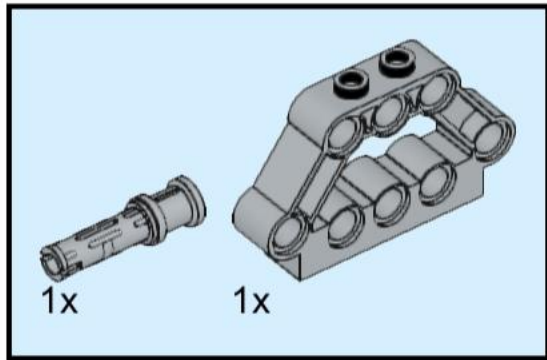

36

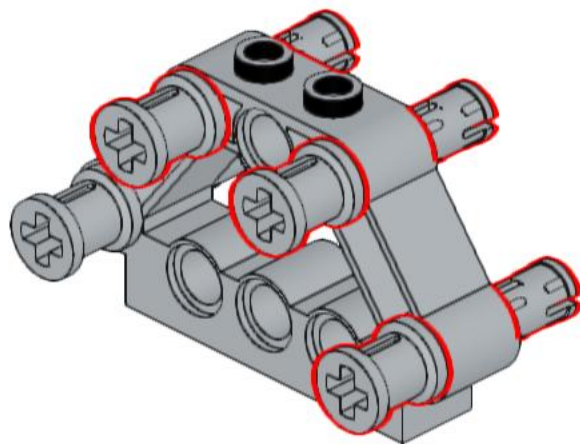
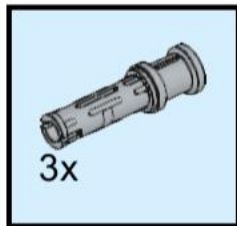

37

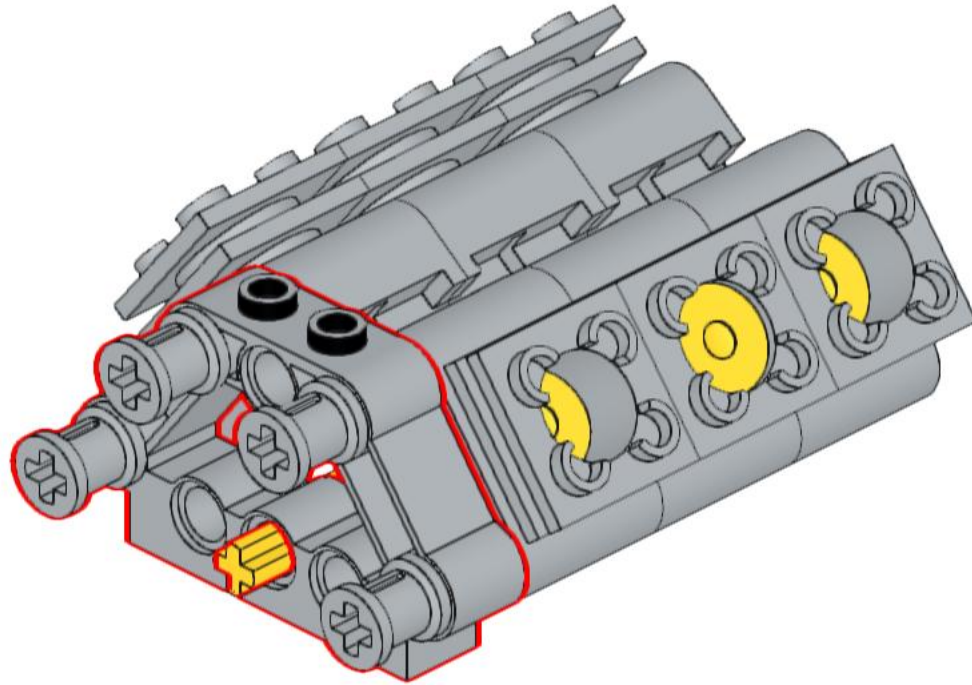

38

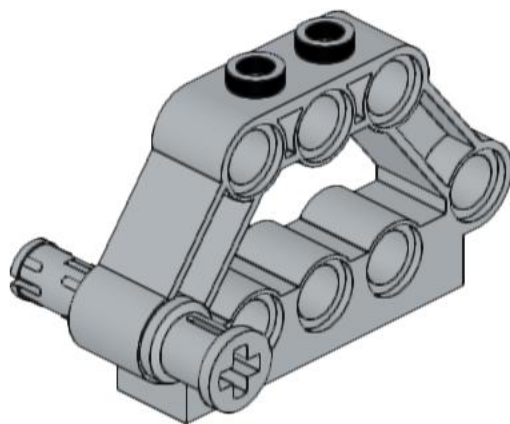
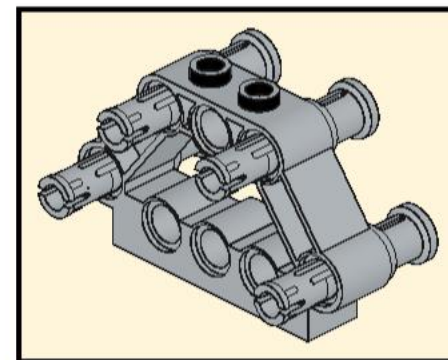
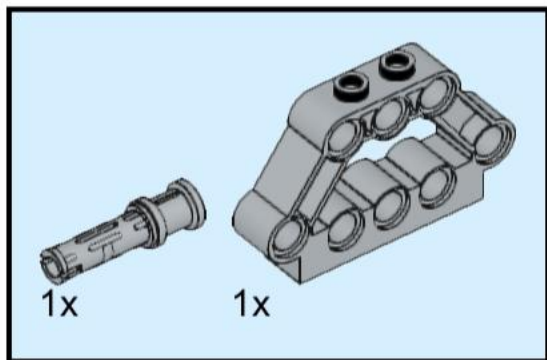

39

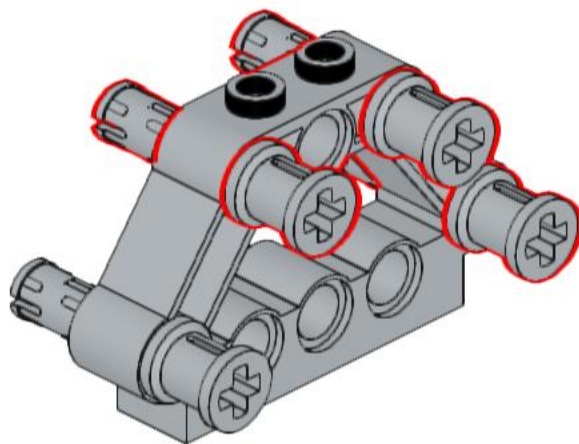
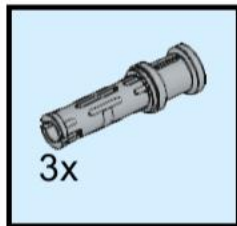

40

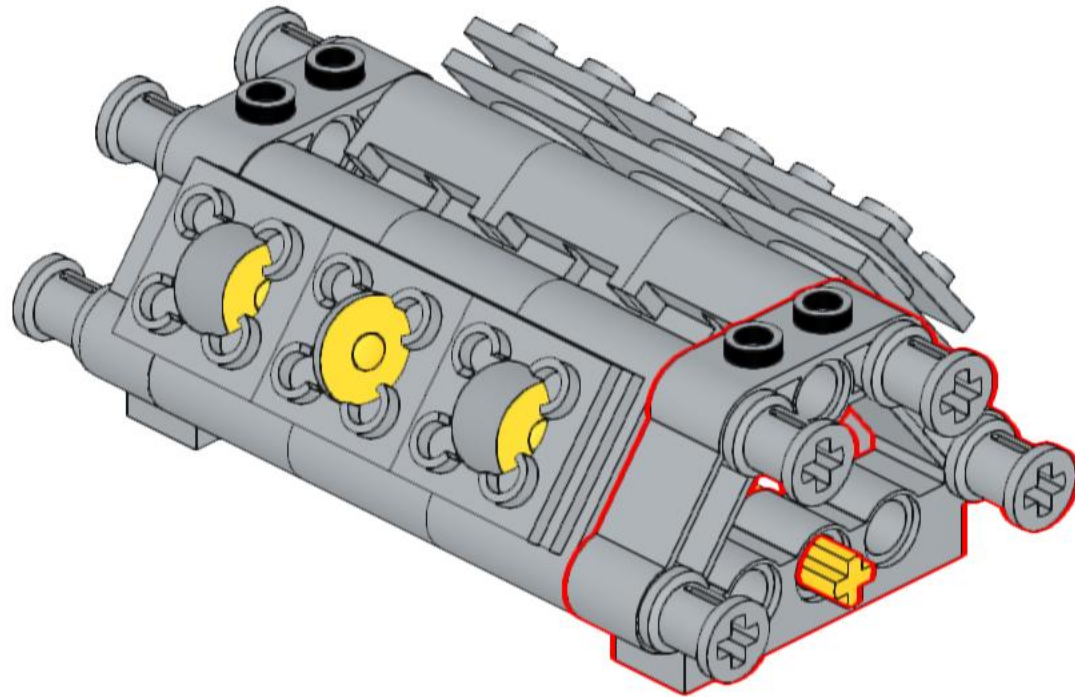

41

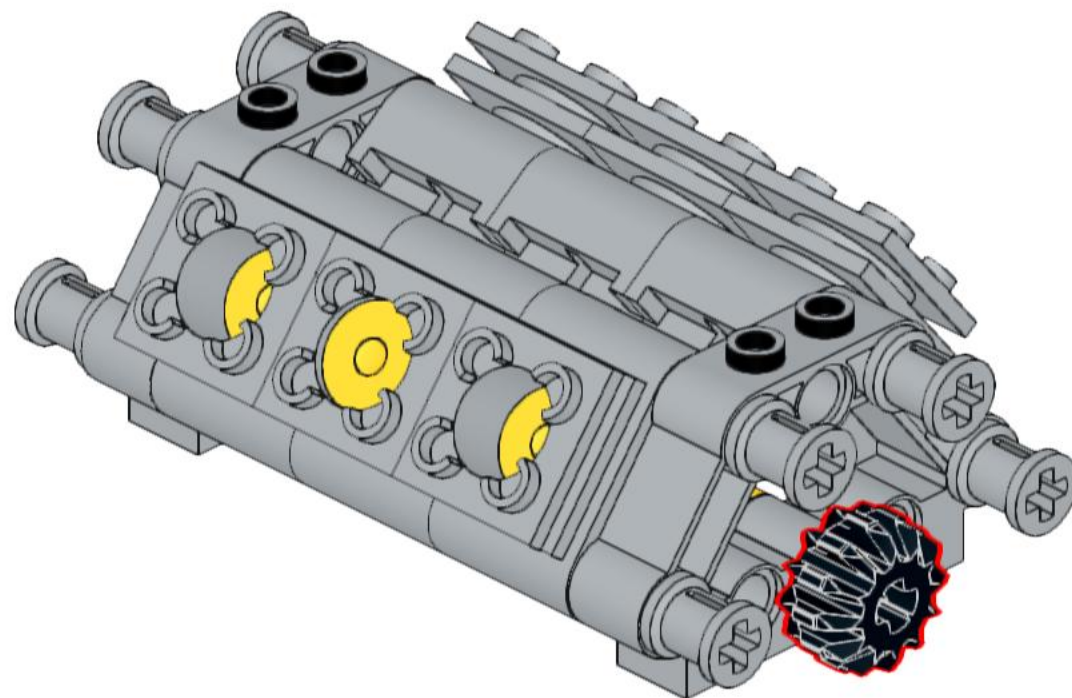
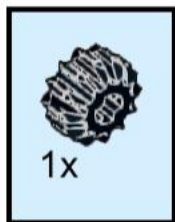

42

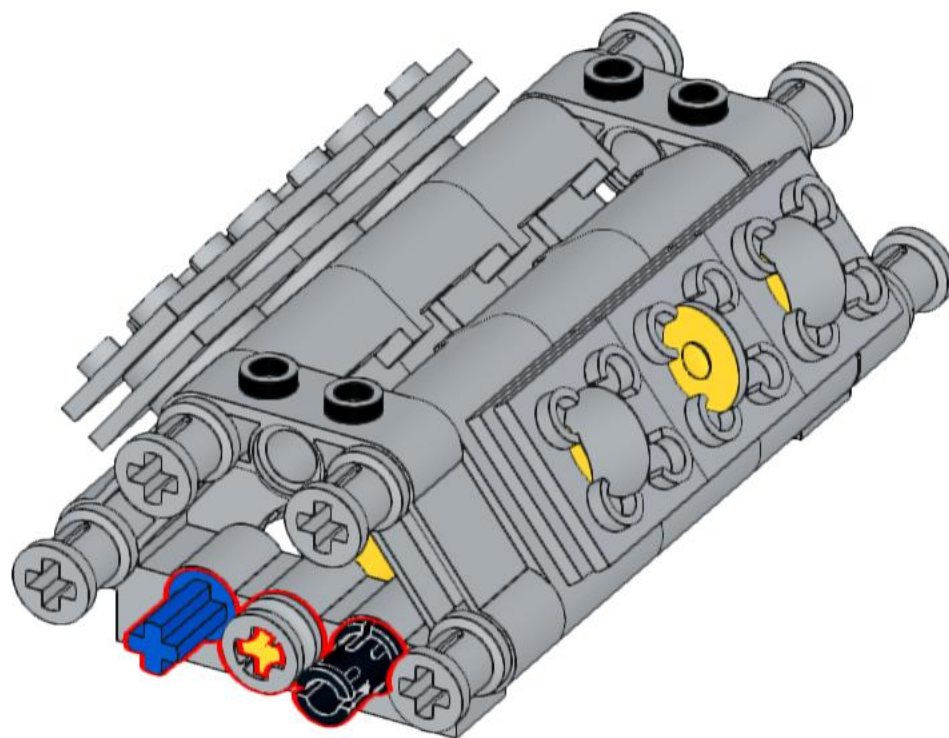
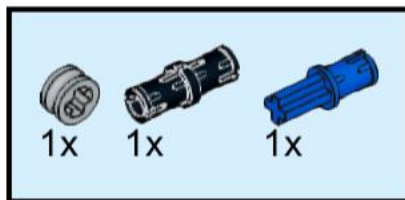

43

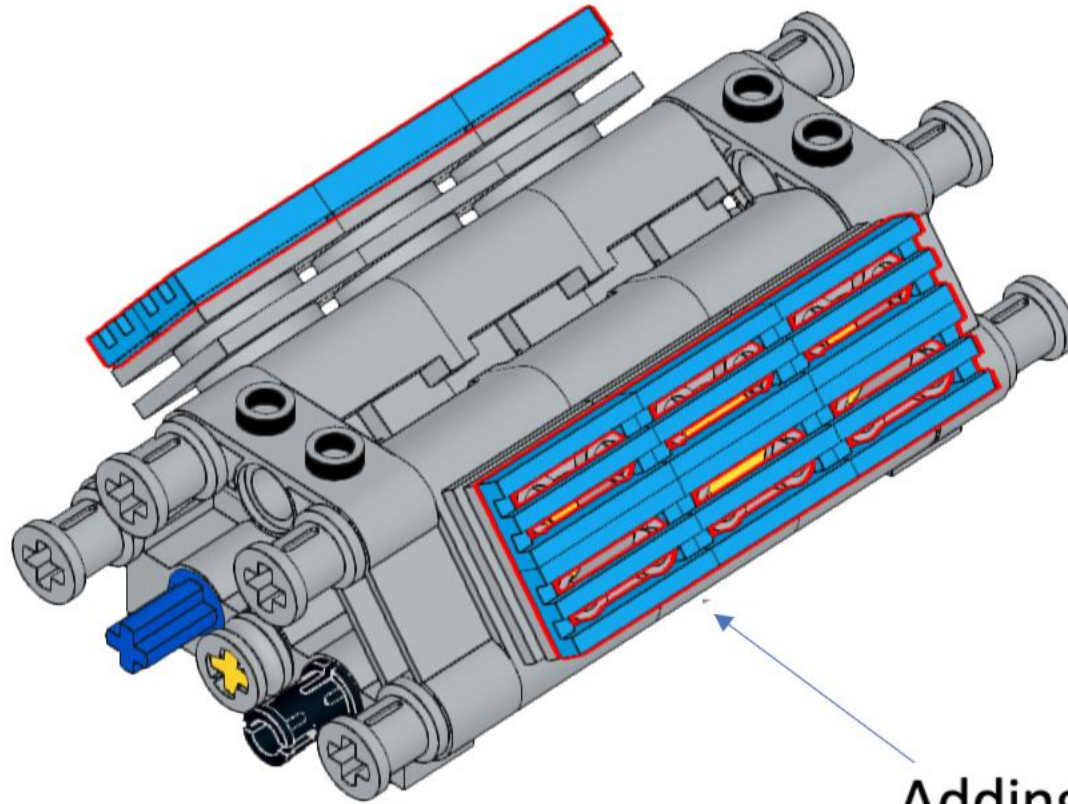
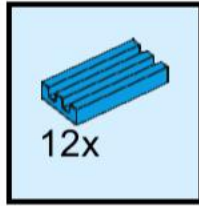

Adding the Cylinder Heads

Making the Compressor – The Cylinder Head

44

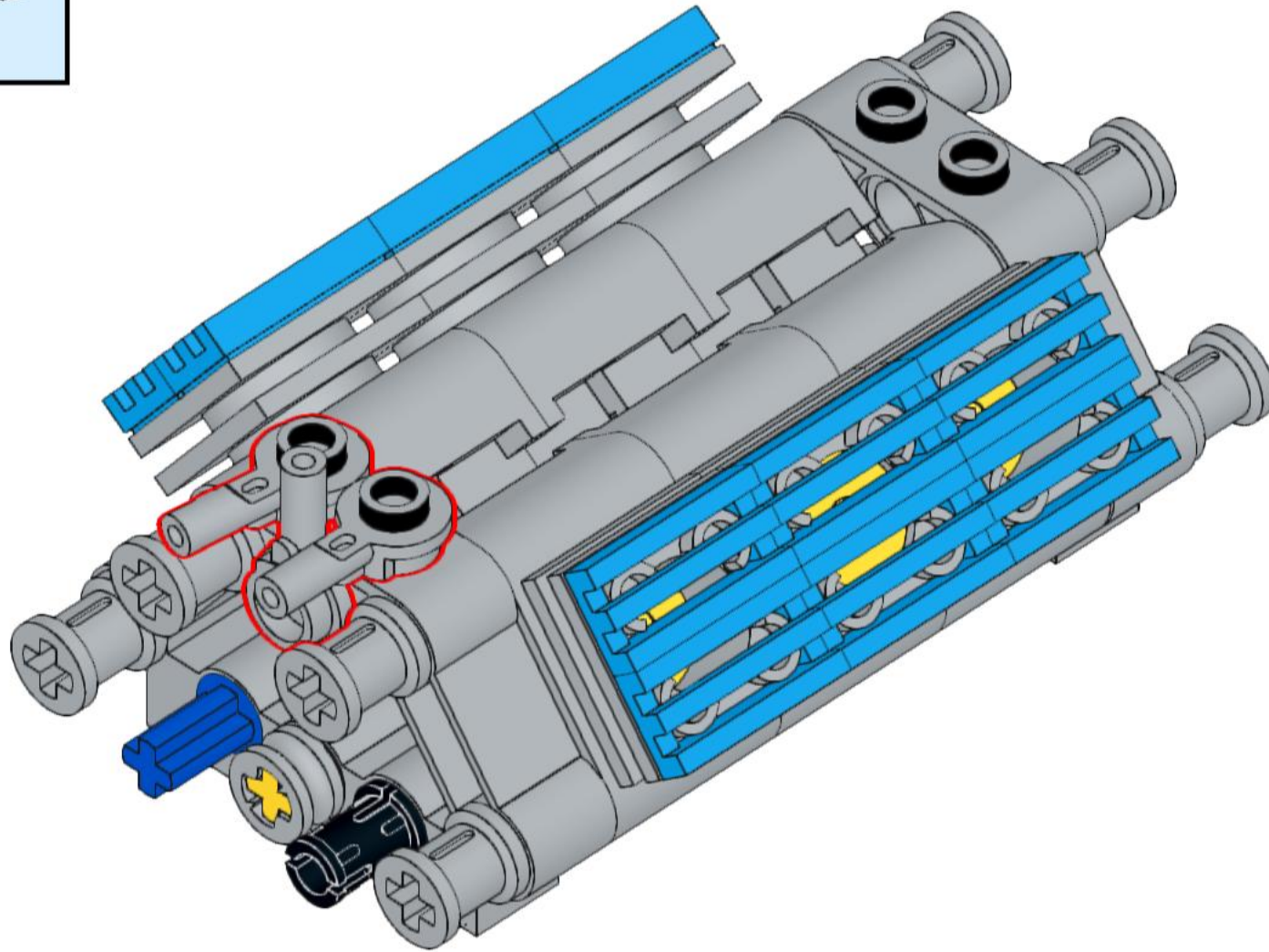
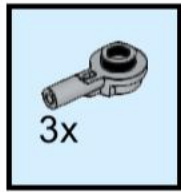

45

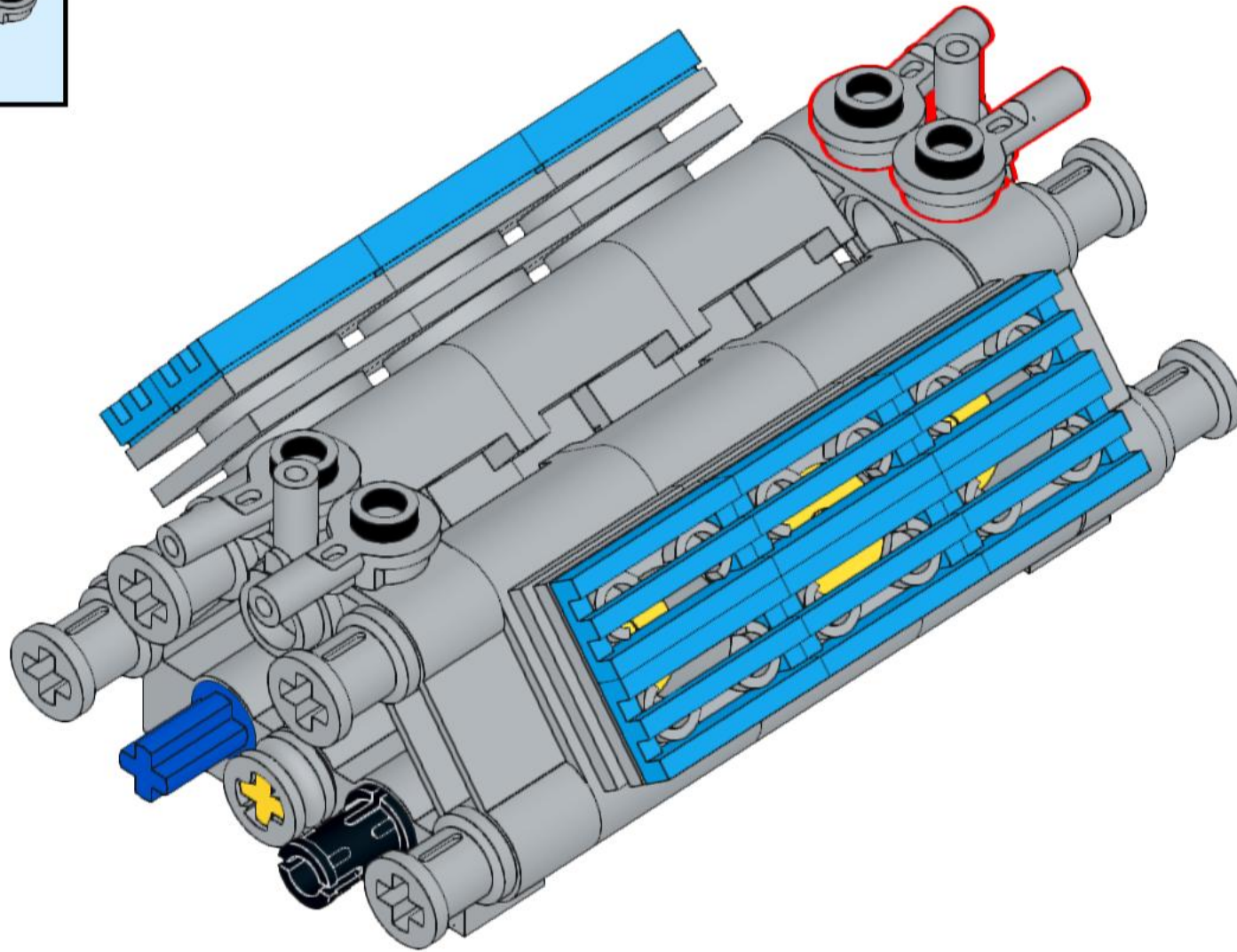
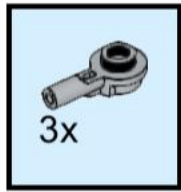

46

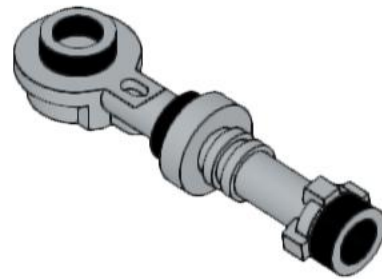
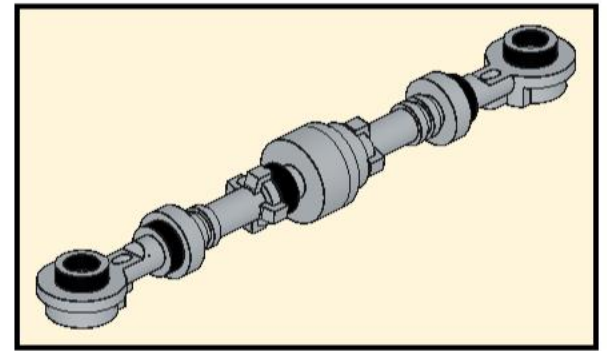
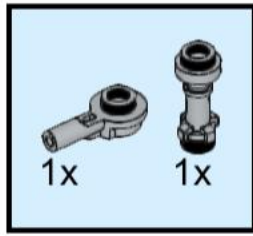

47

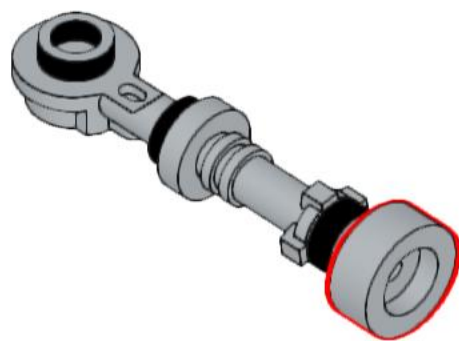
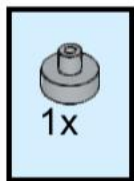

48

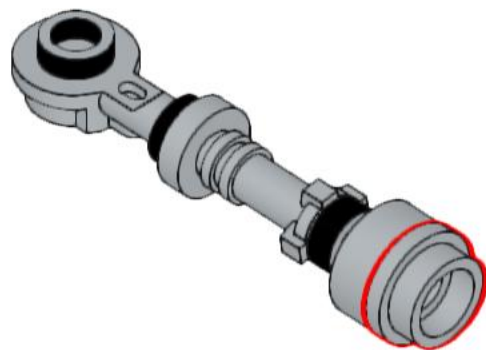
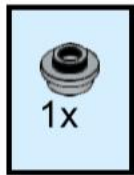

49

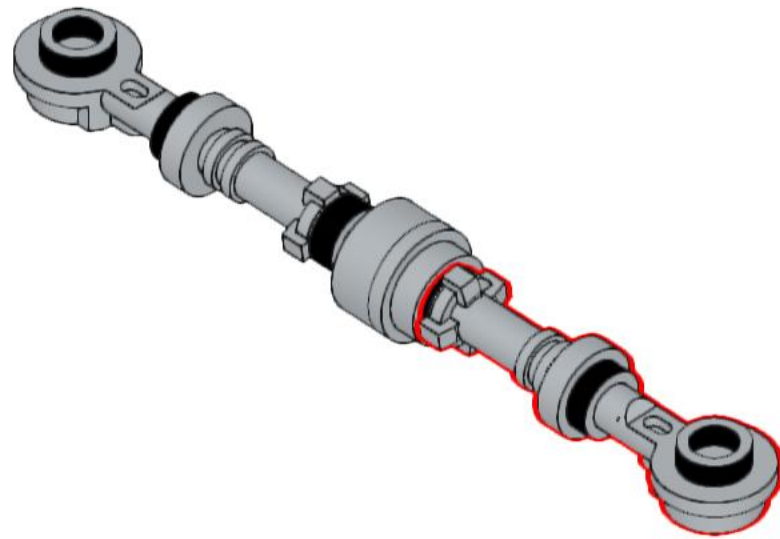
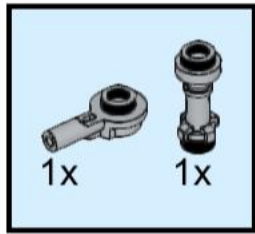

50

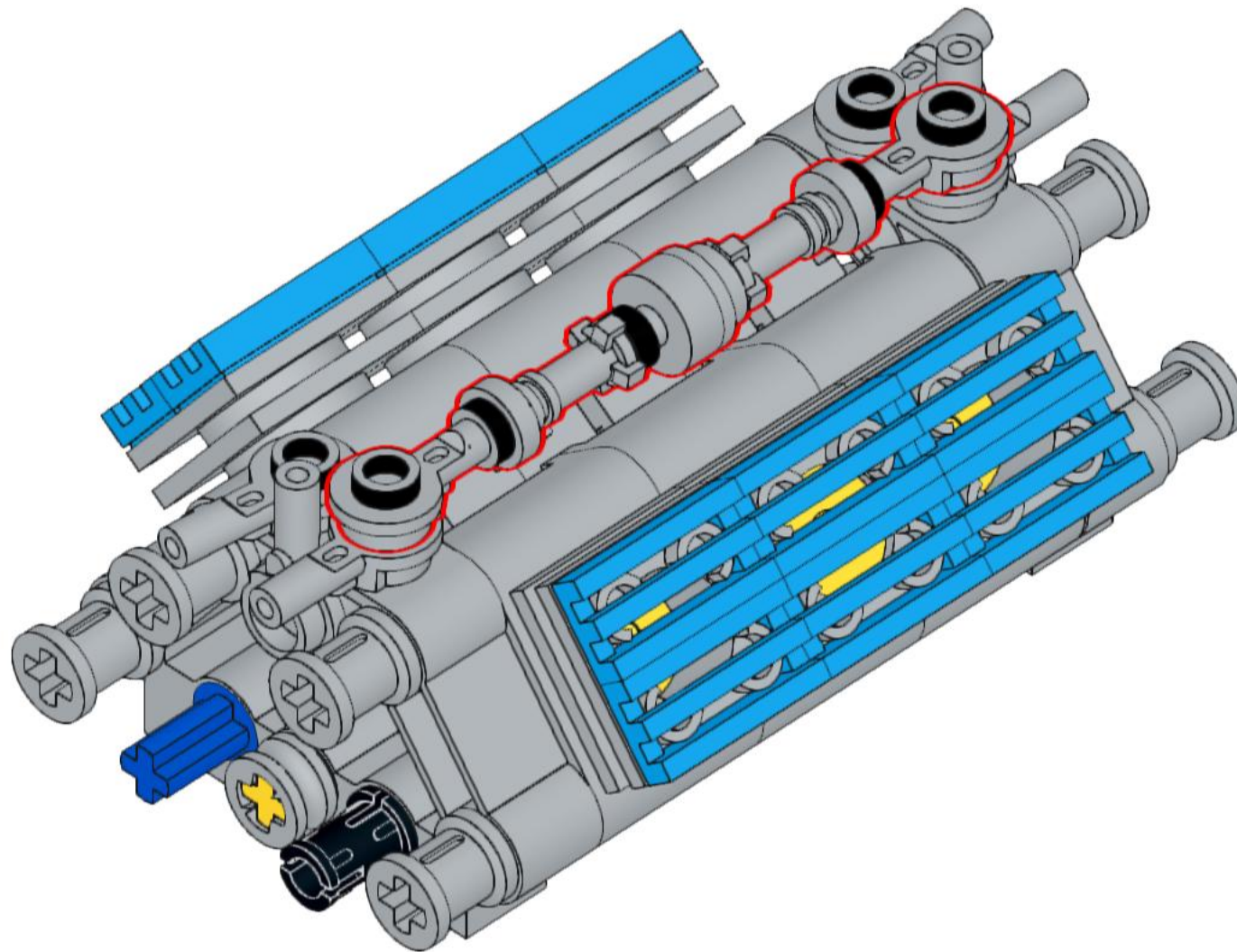

51

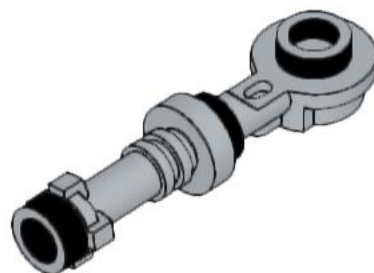
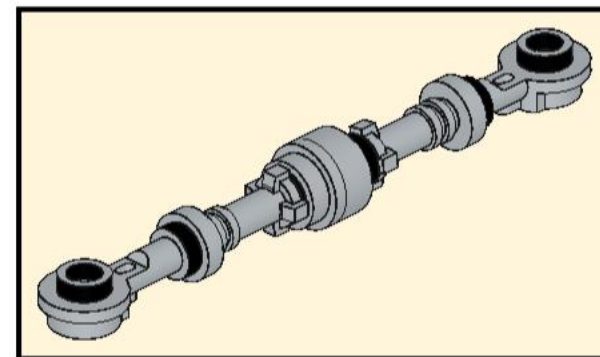
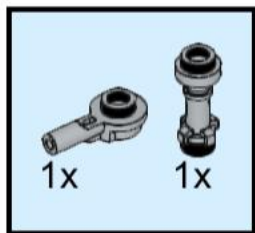

52

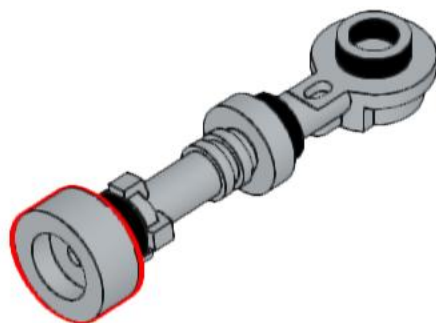
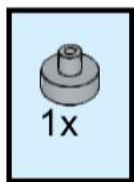

53

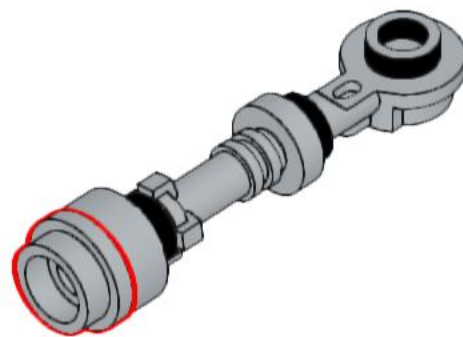
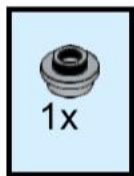

54

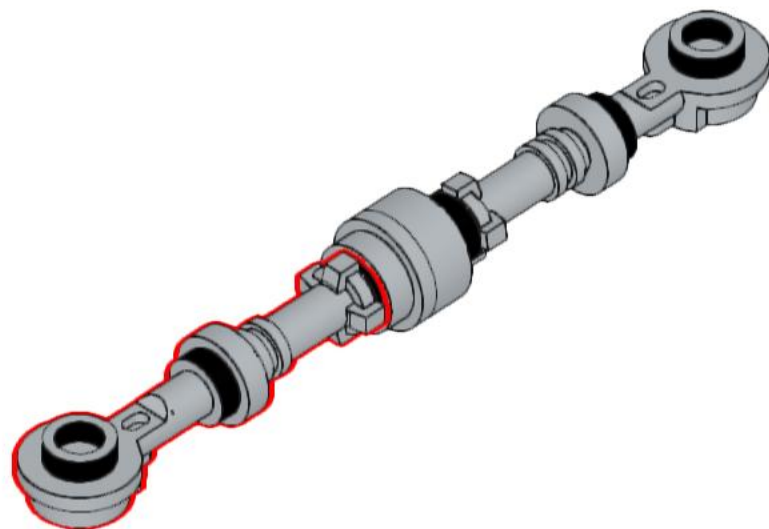
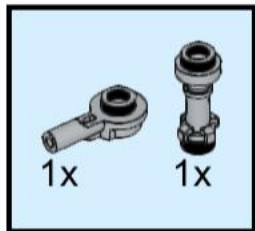

55

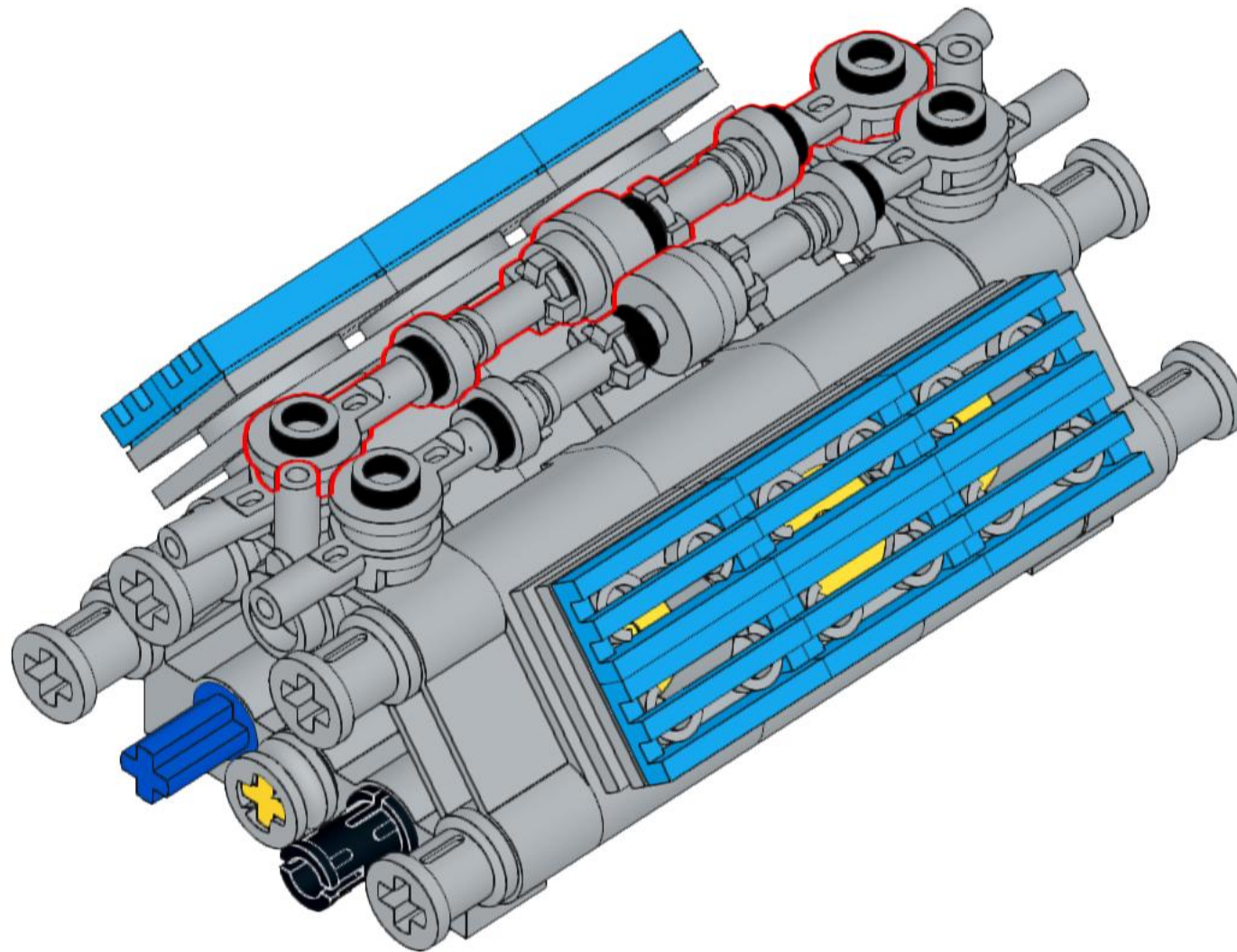

56

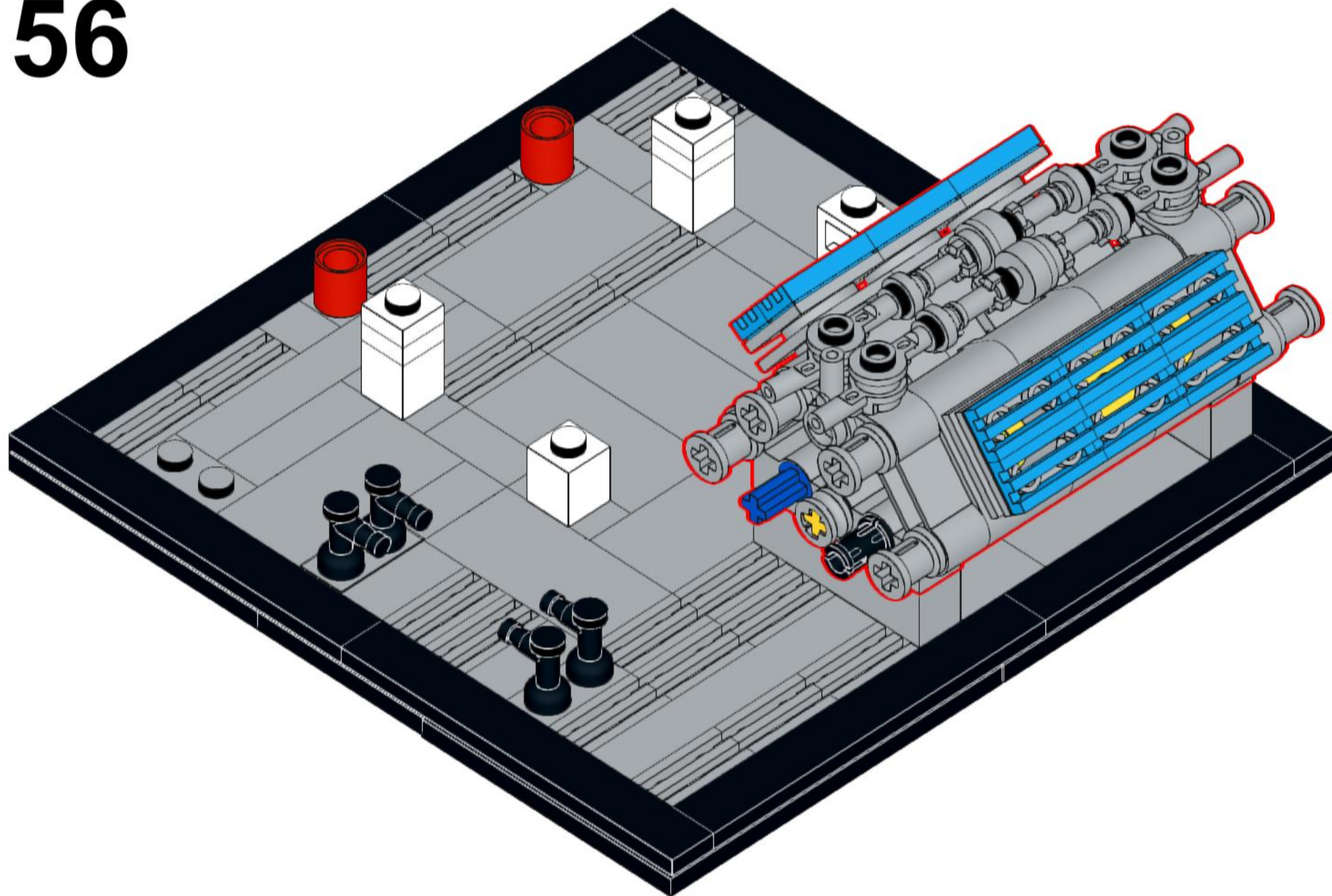

57

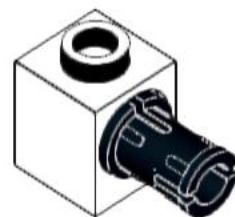
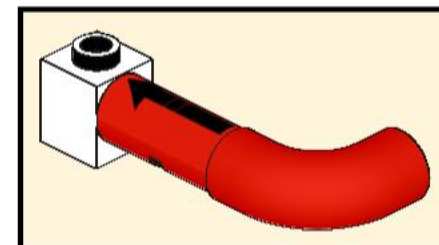
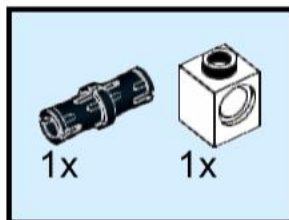

Adding the Discharge Line

The Discharge Line takes the heated pressurised gas from the compressor to the condenser.

58

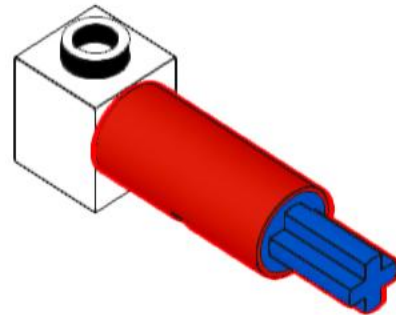
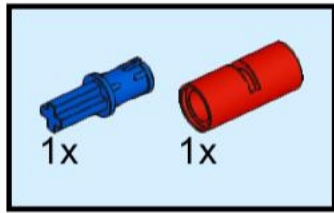

59

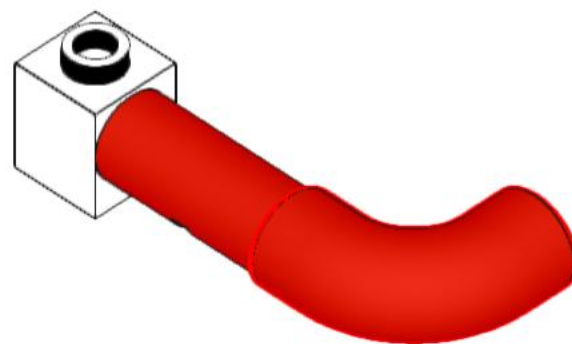
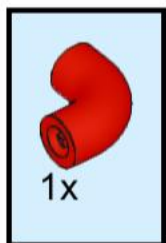

60

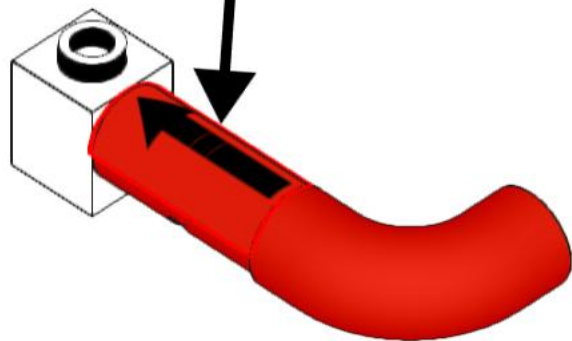
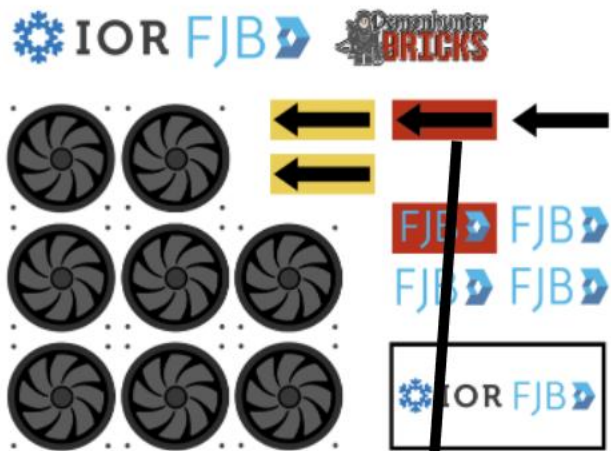

61

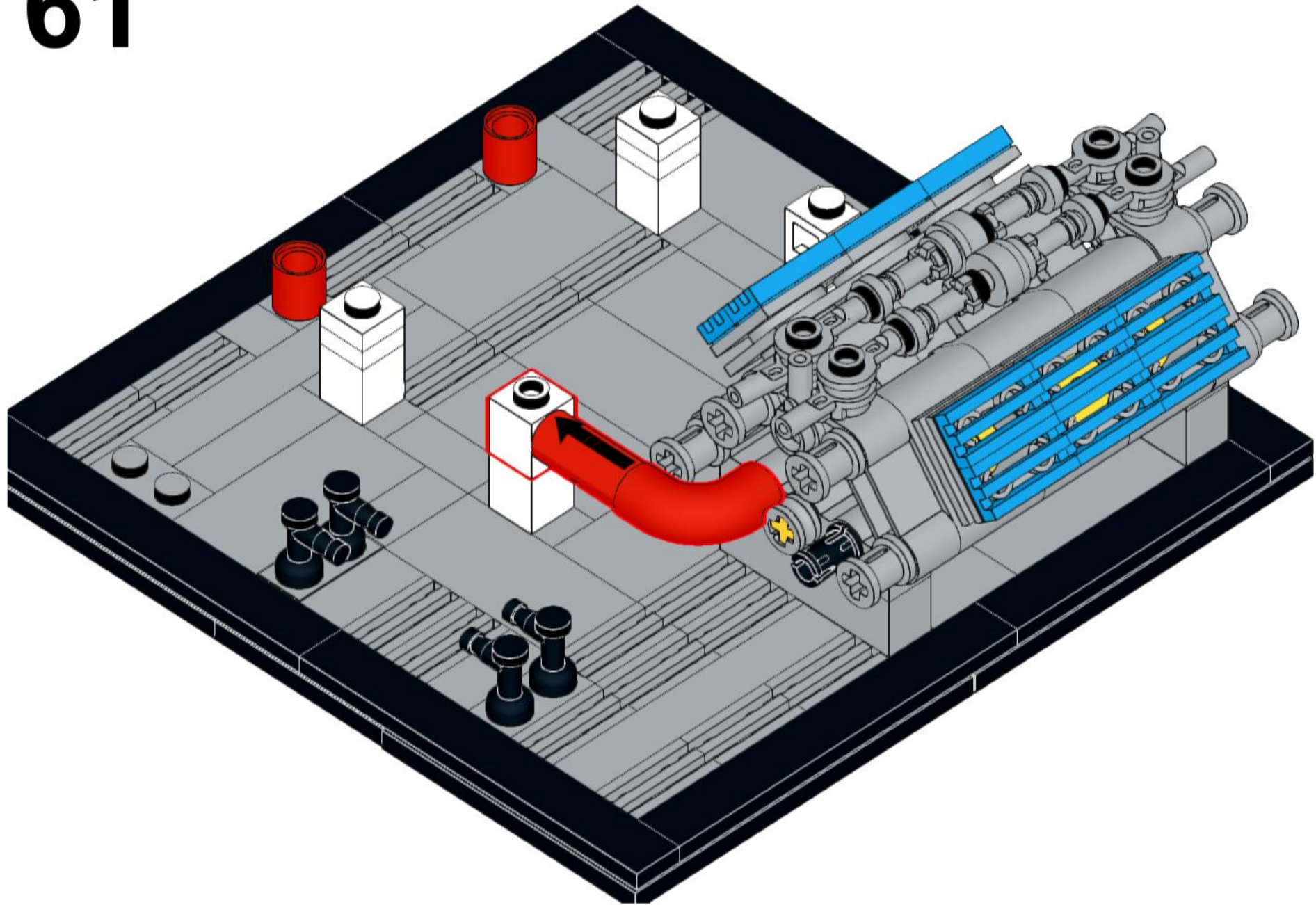

The Condenser

The purpose of the Condenser is to 'change the state' of the Refrigerant from a gas to a liquid. This relies on the **principle of heat exchange** in that, heat will naturally flow from a higher temperature to a lower temperature.

As the heated pressurised gas (from the Compressor) travels through the coils of the condenser, the heat of the gas will naturally flow to the cooler 'outside air' reducing the temperature of the refrigerant until it 'changes state' from a gas to a saturated liquid. This process is known as condensation. The fans increase the air flow over the coil increasing the heat transfer.

The Refrigerant is now a high pressure, high temperature liquid and will leave the Condenser via the Condensed Liquid pipe to be stored in the Liquid Receiver.

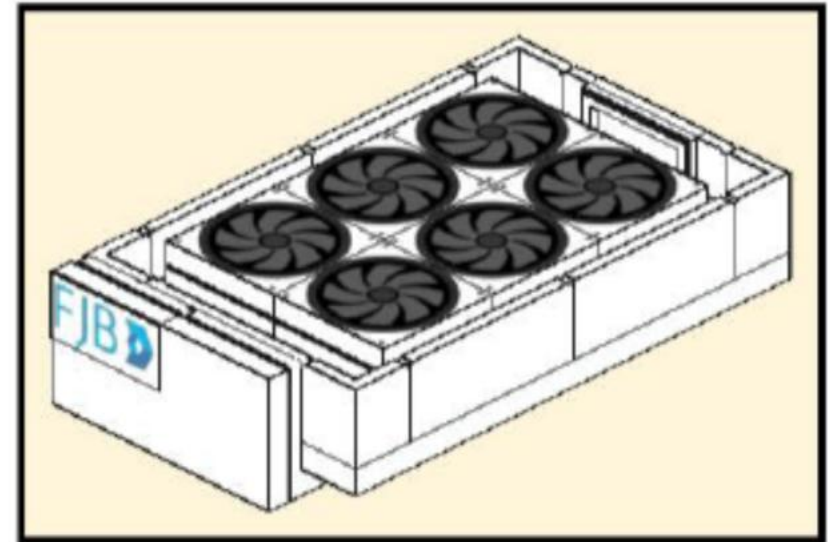

For more information on condensers visit:

<https://www.fantasticfridges.com/AdvancedTopics/InsideARefrigerationSystem>

62

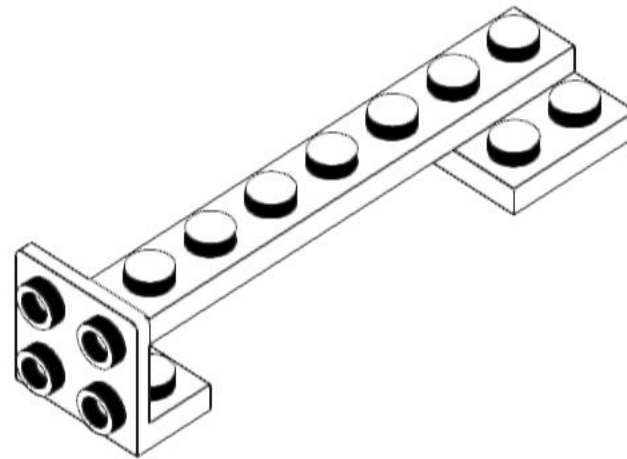
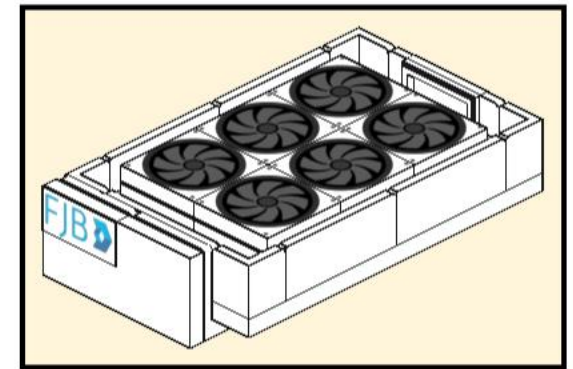
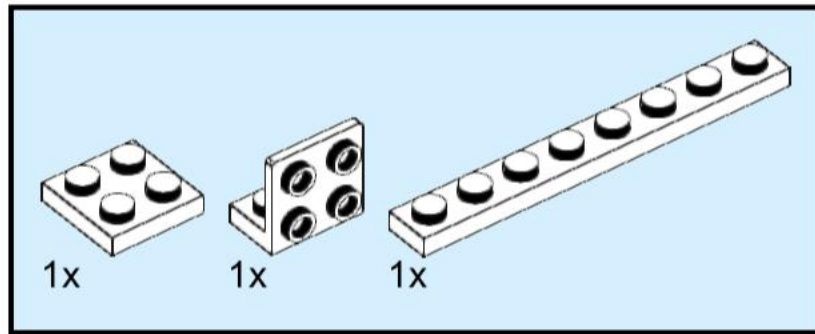

63

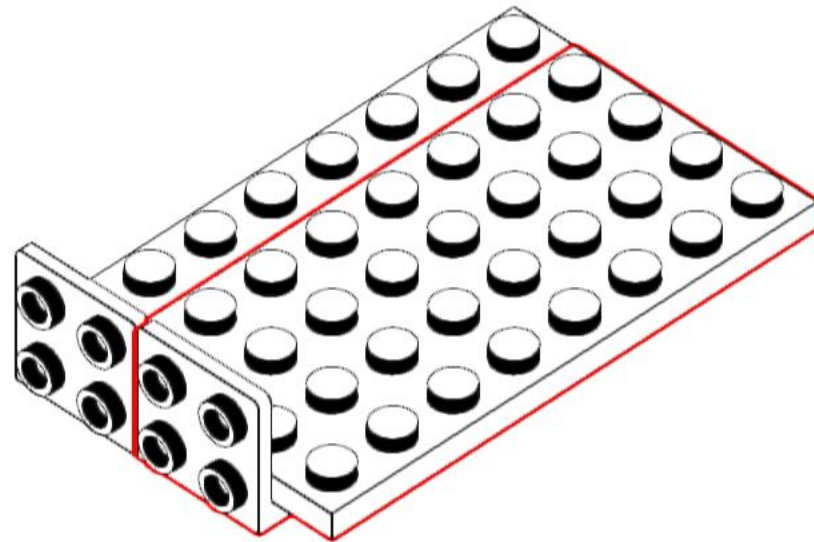
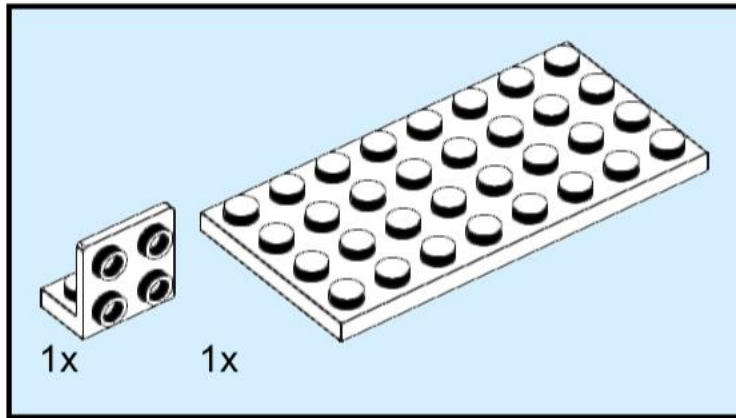

64

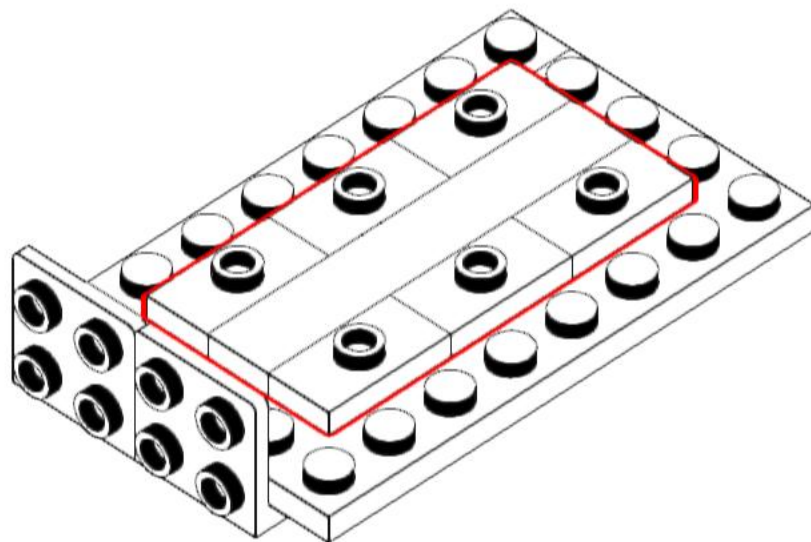
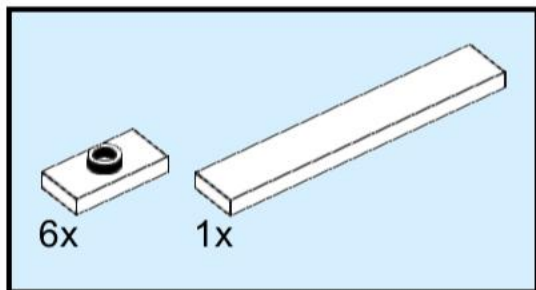

65

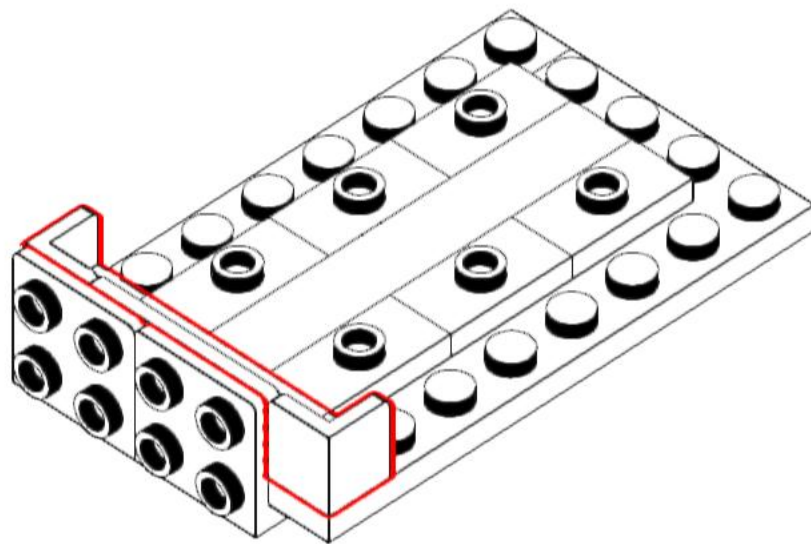
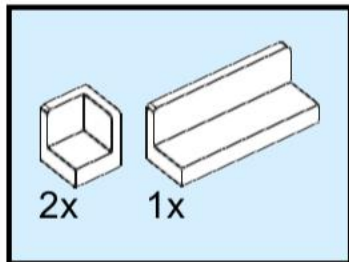

66

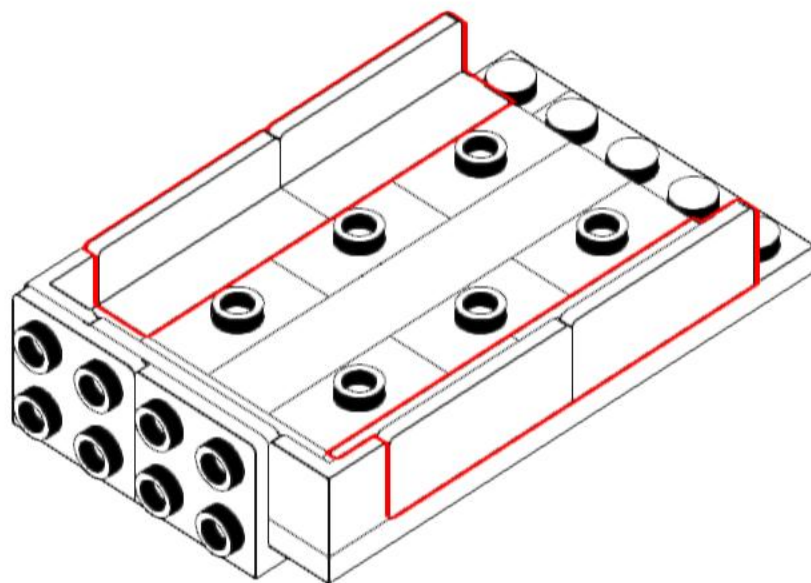
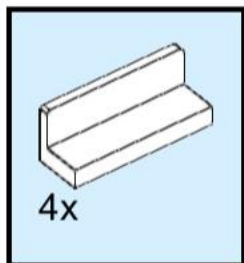

67

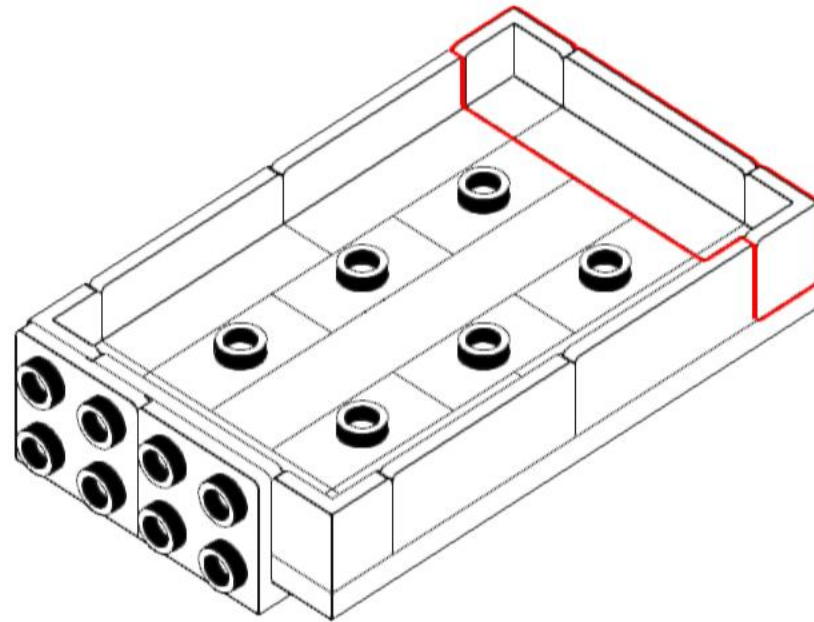
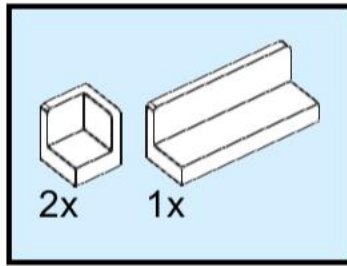

68

IOR FJB  

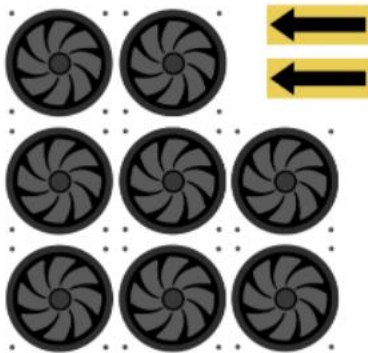

FJB  FJB 
FJB  FJB 

 IOR FJB 

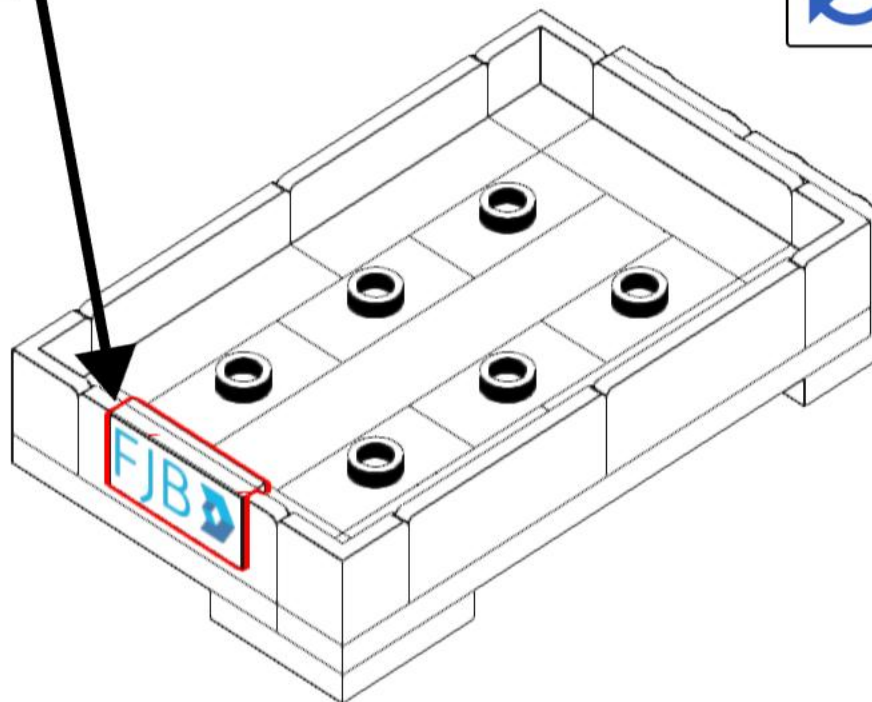

69

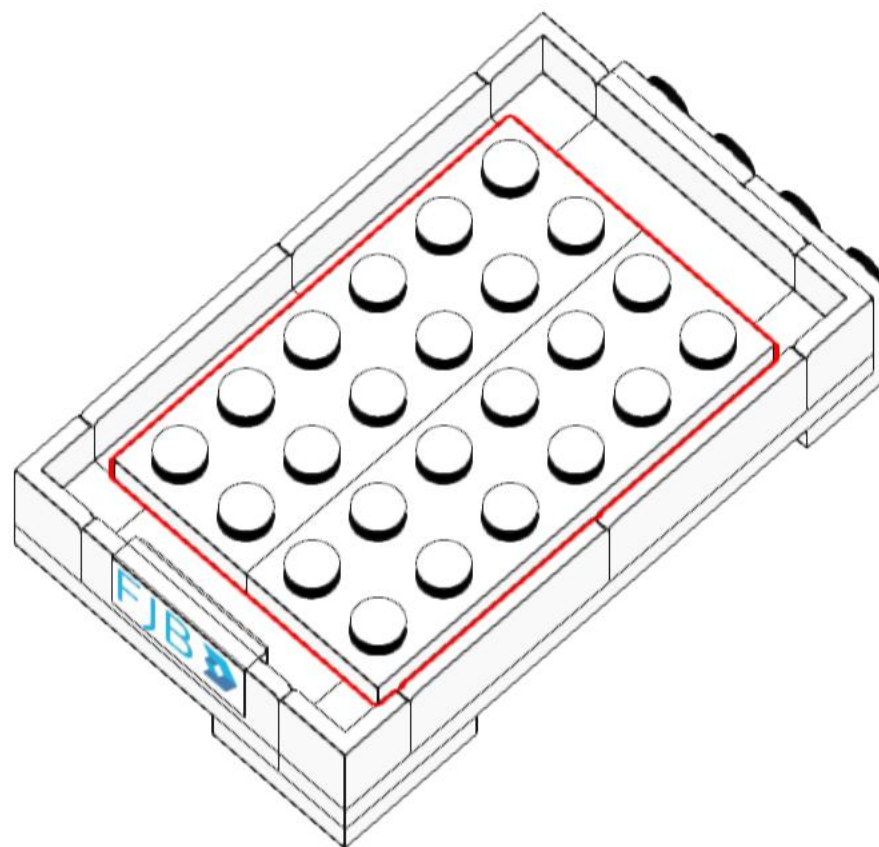
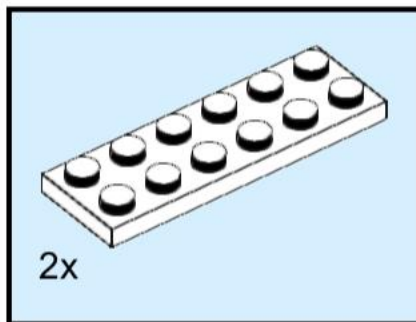

70

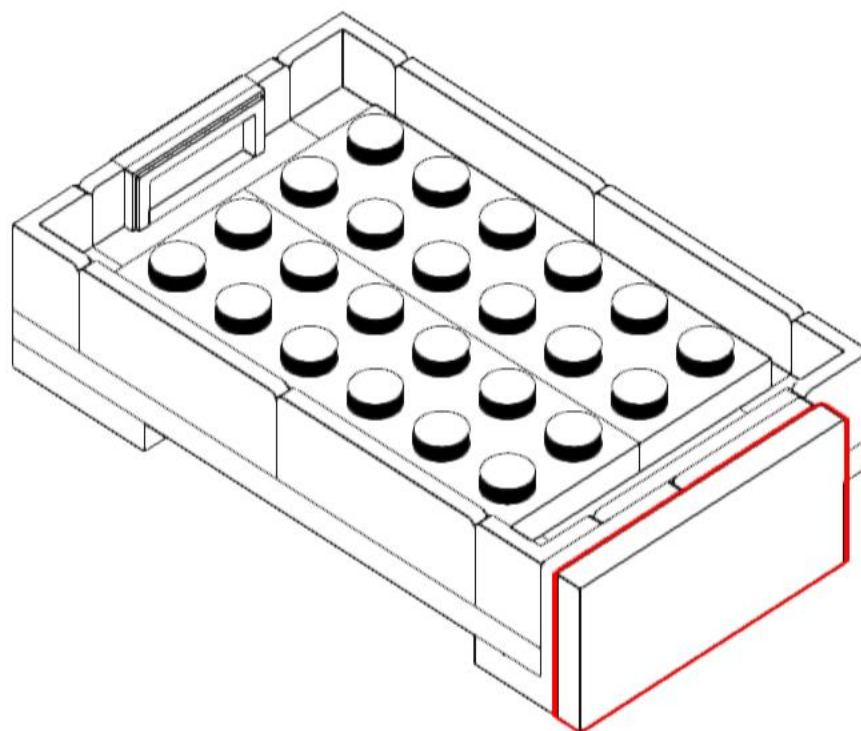
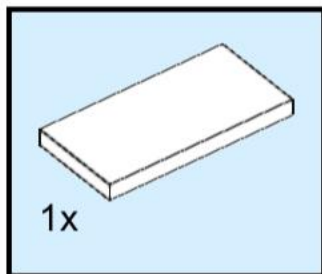

71

IOR FJB  **Computer BRICKS**

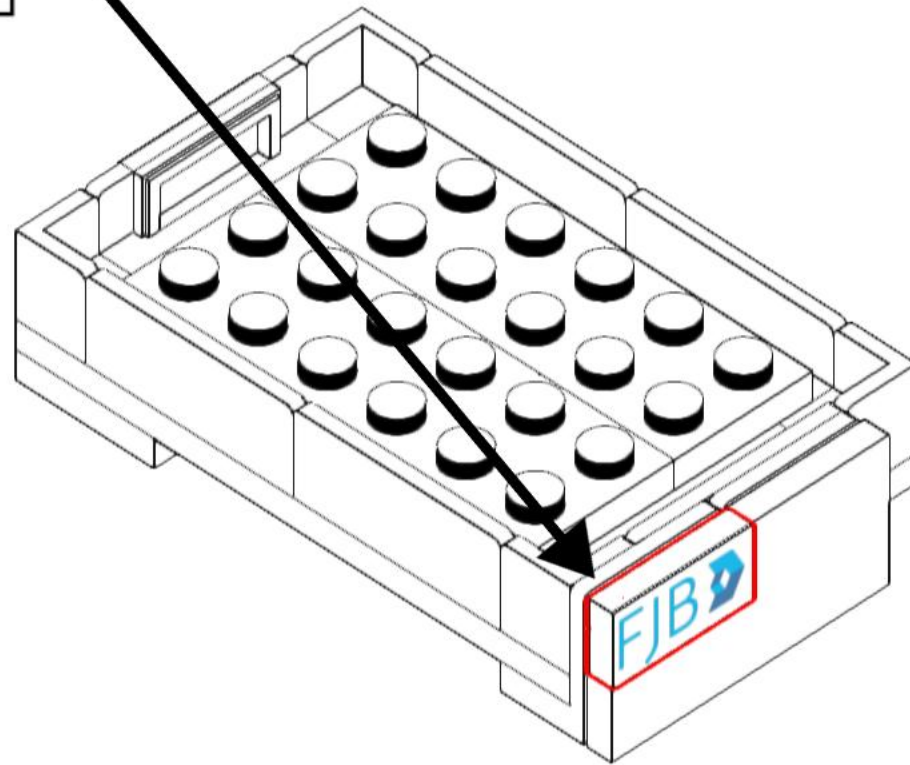
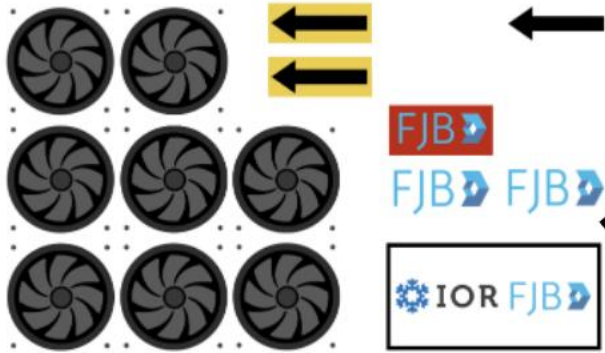

72

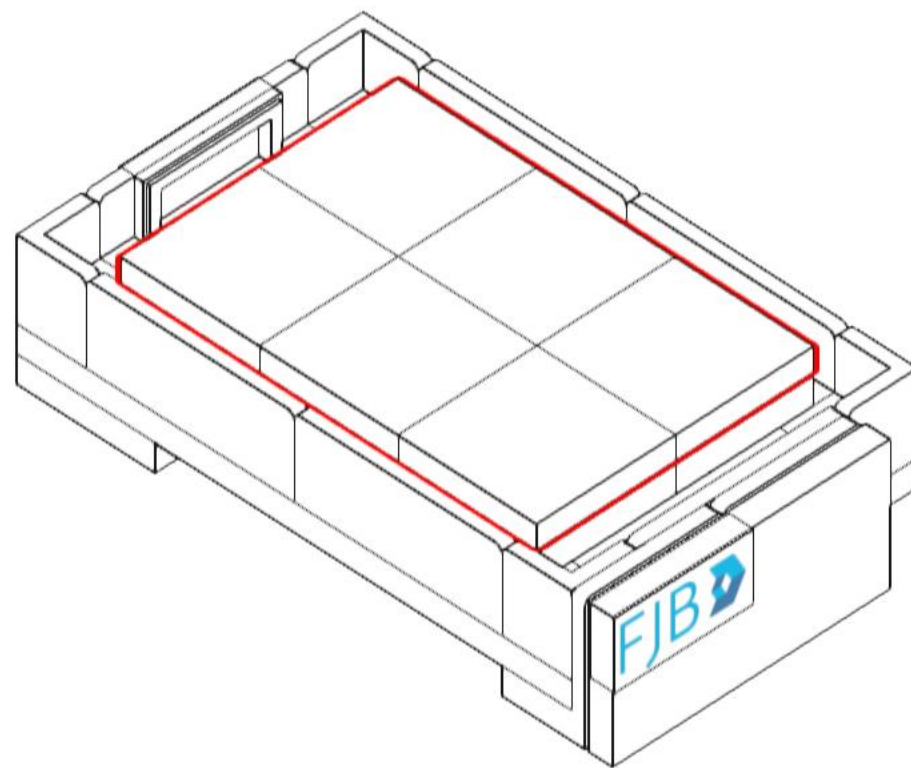
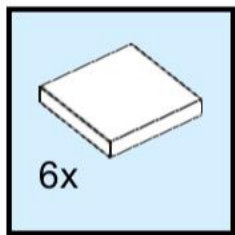

73

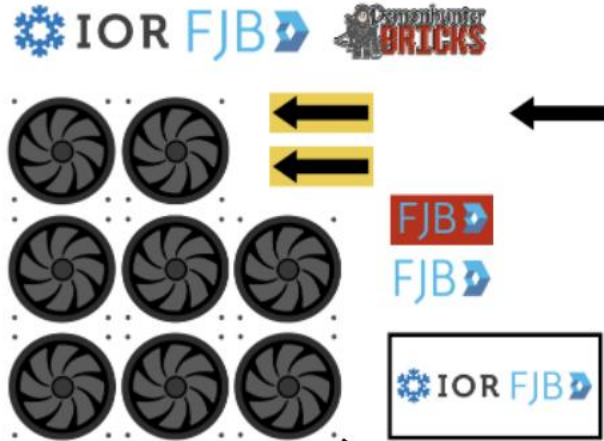

x6

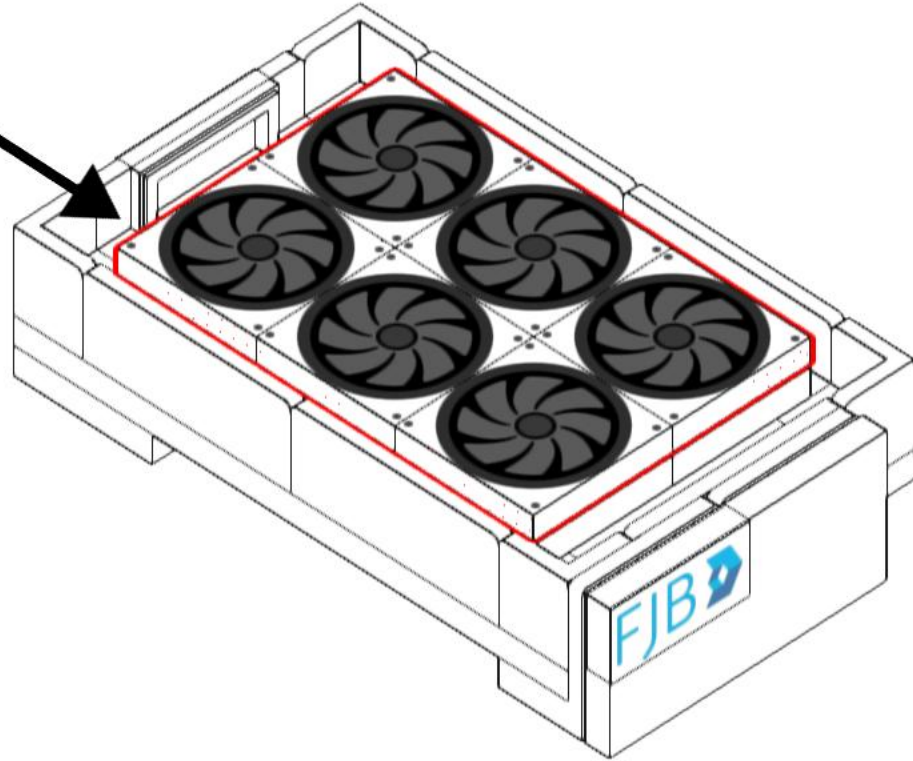

74

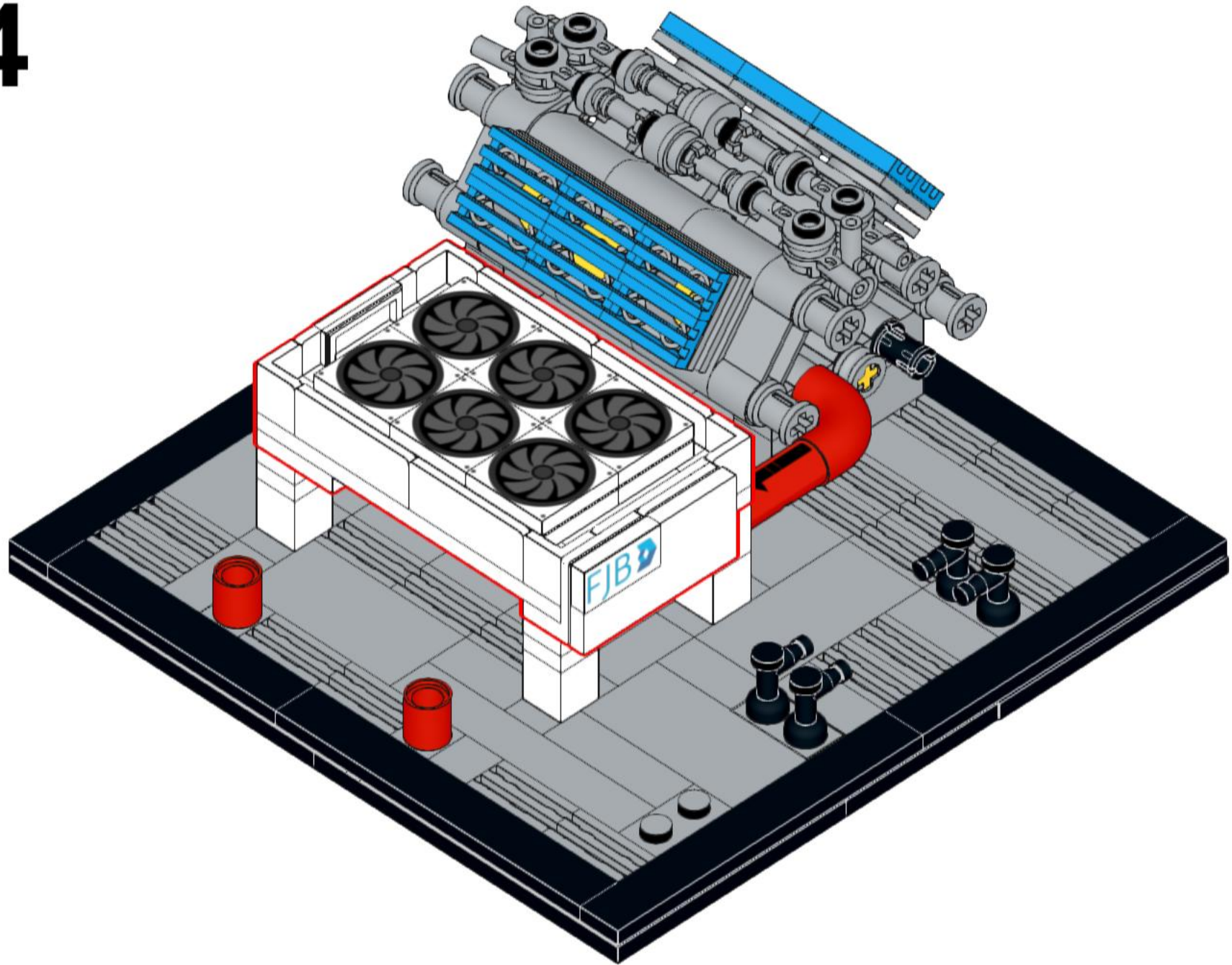

75

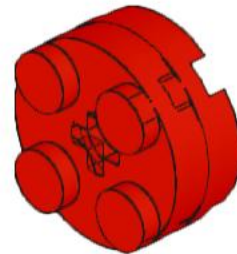
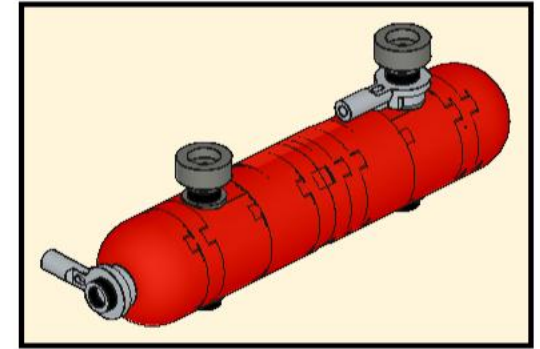
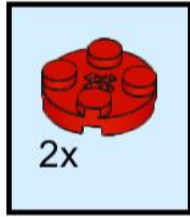

Making the Liquid Receiver

The Liquid Receiver is a storage vessel designed to hold excess refrigerant which is not in circulation, before it moves to the Expansion Valve.

76

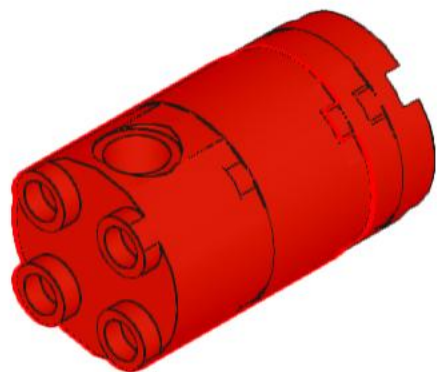
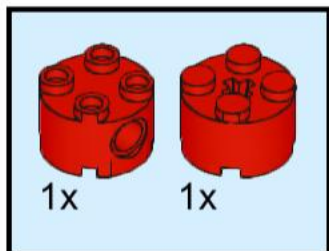

77

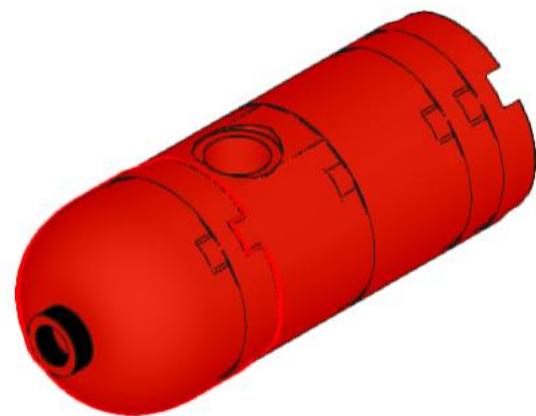
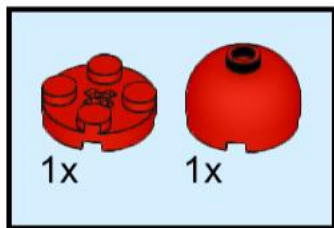

78

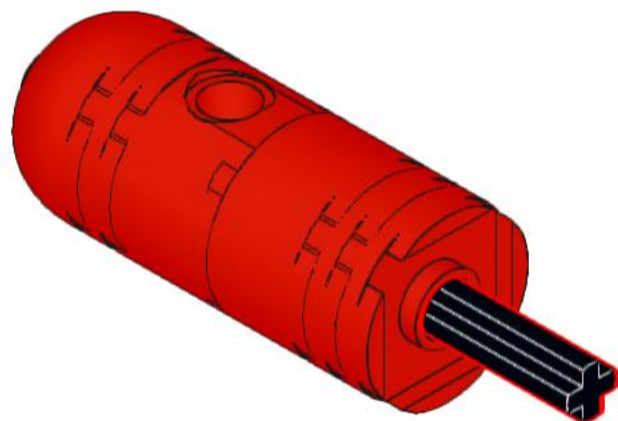
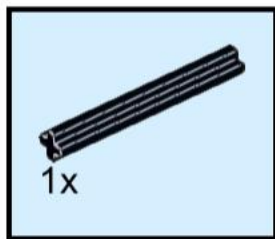

79

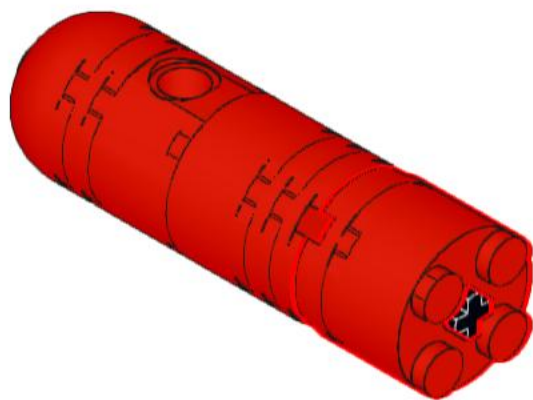
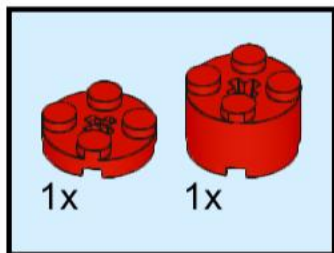

80

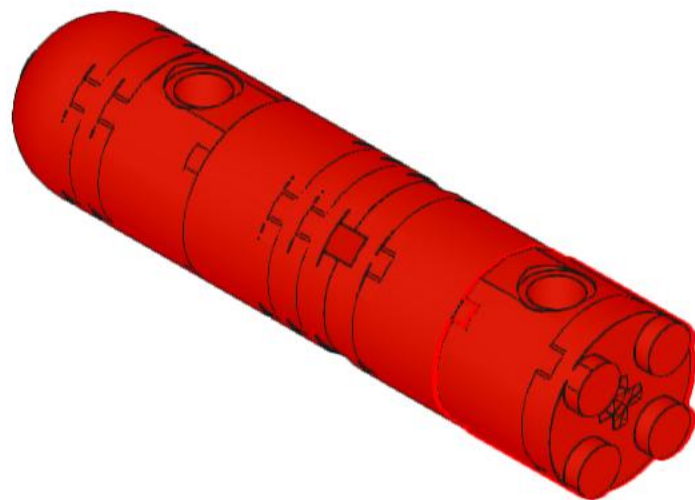
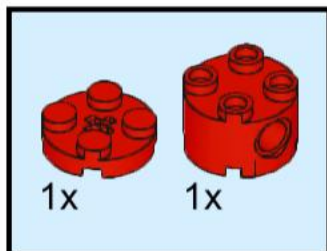

81

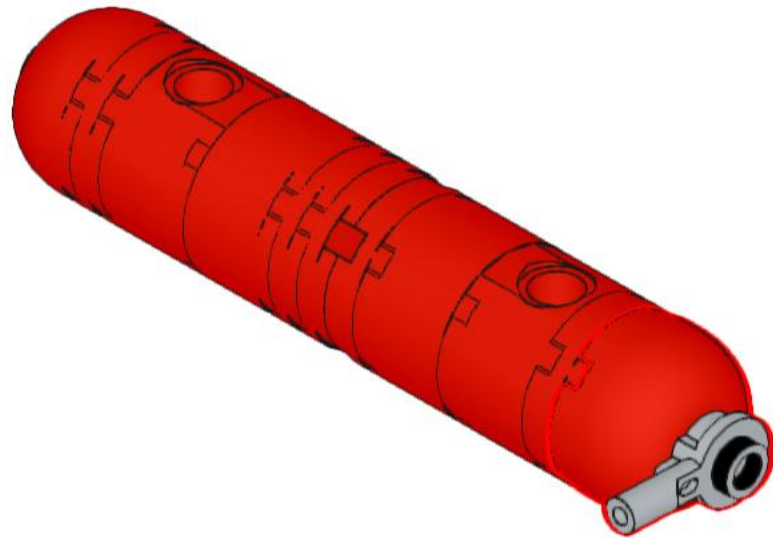
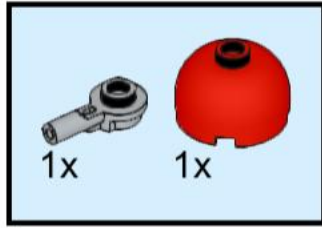

82

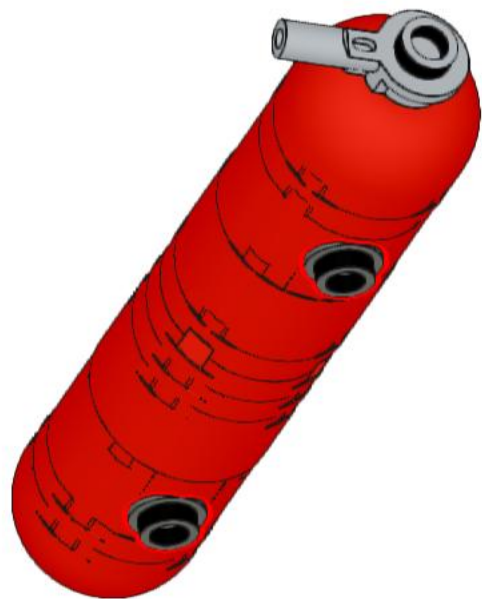

83

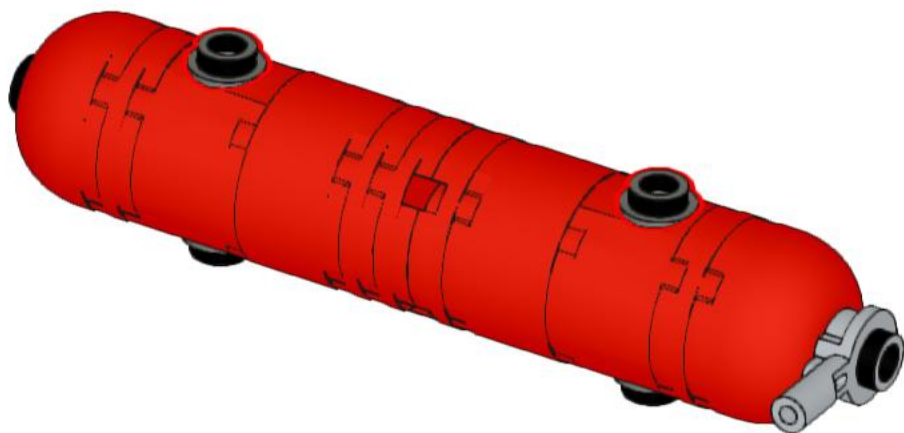

84

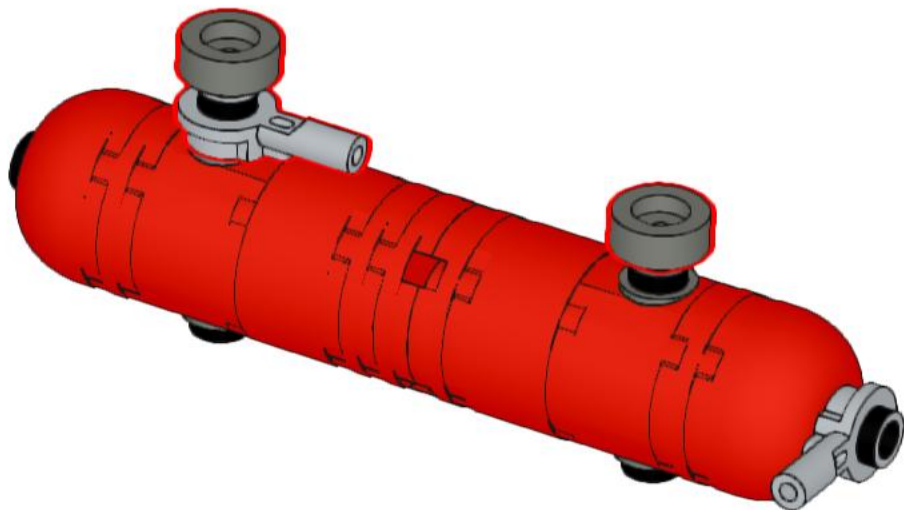
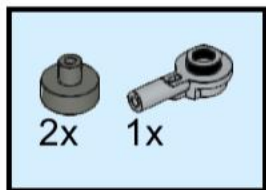

85

IOR FJB Demonhunter BRICKS

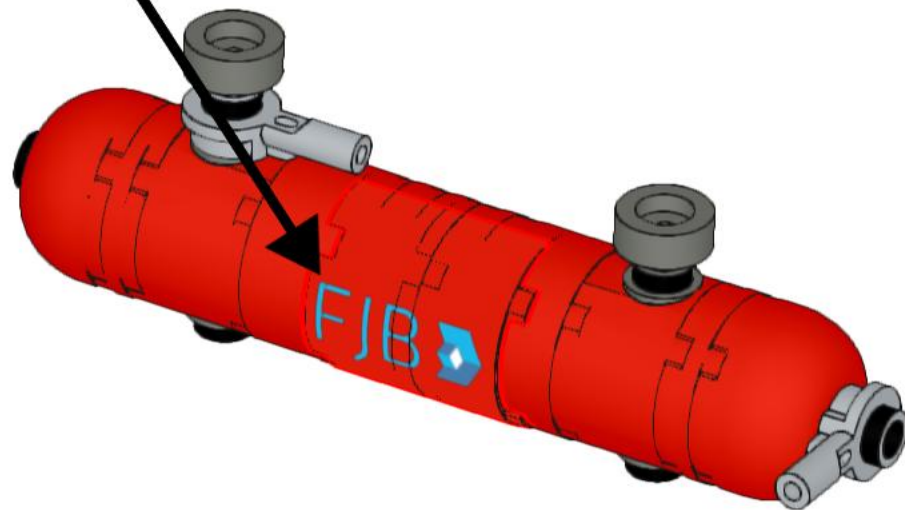
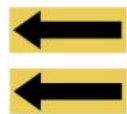

86

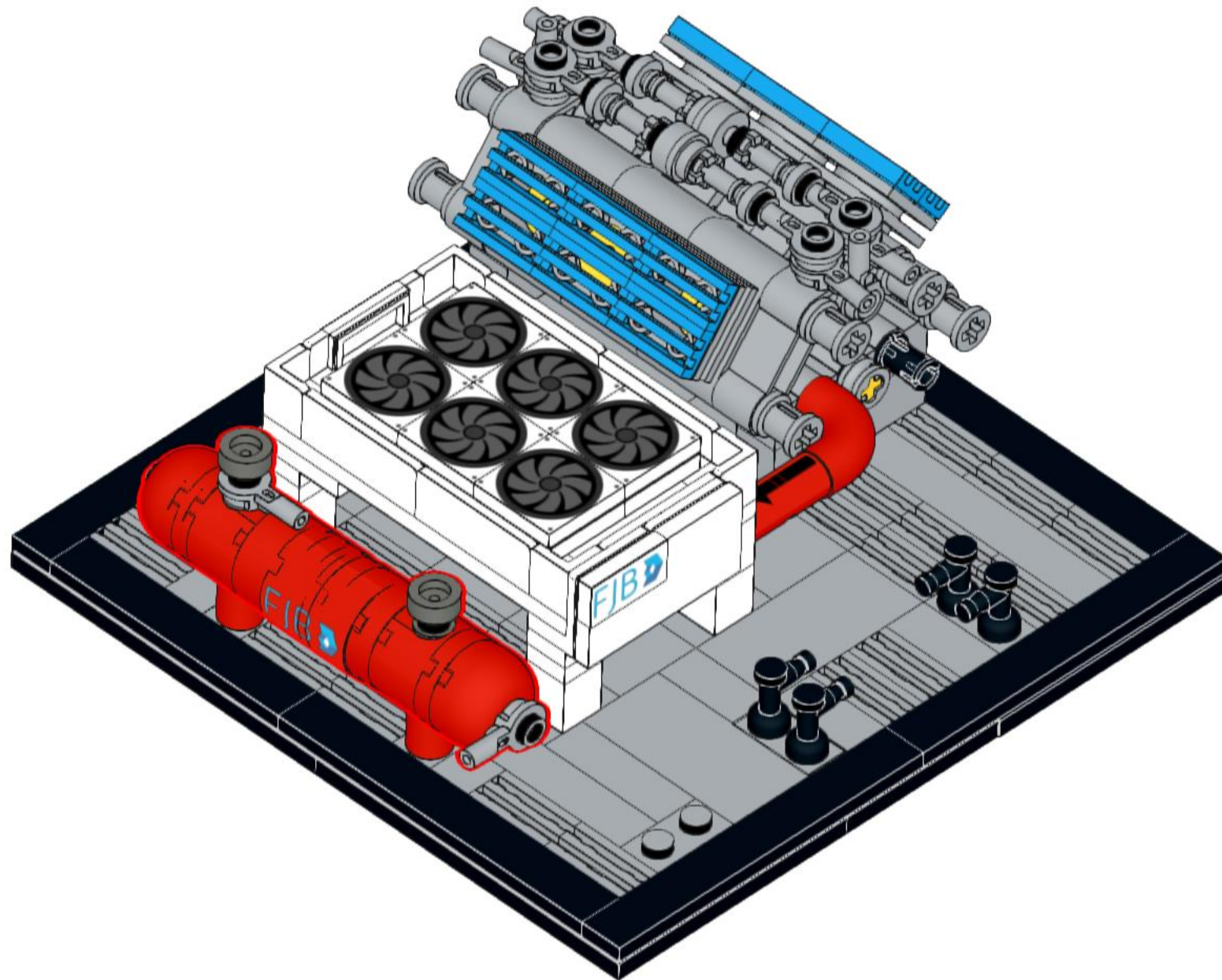

87

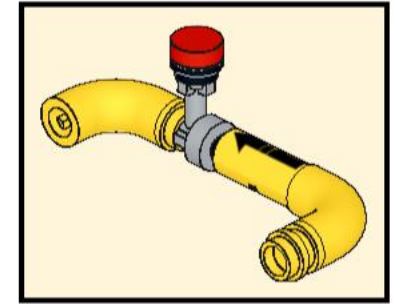

The Condensed Liquid Pipe

The Condensed Liquid Pipe takes the Refrigerant in its high pressure, high temperature liquid form from the Condenser to the Liquid Receiver.

88

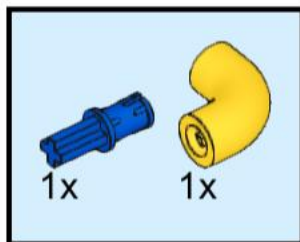

89

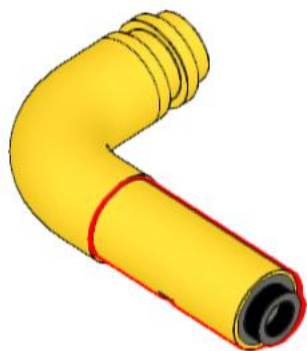
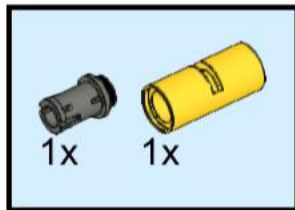

90

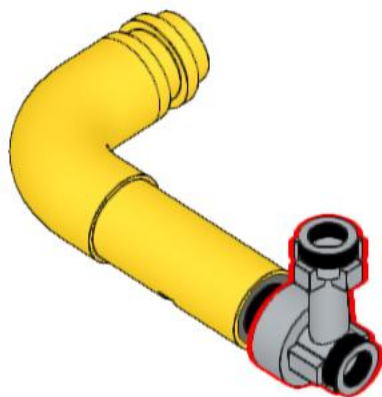
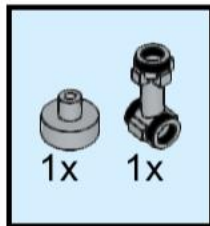

91

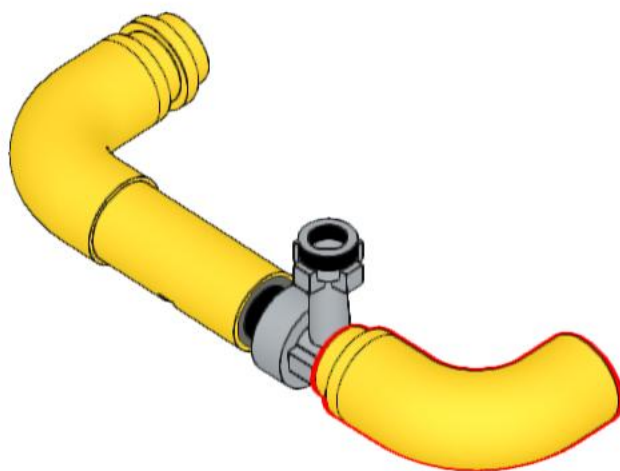
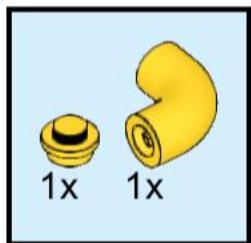

92

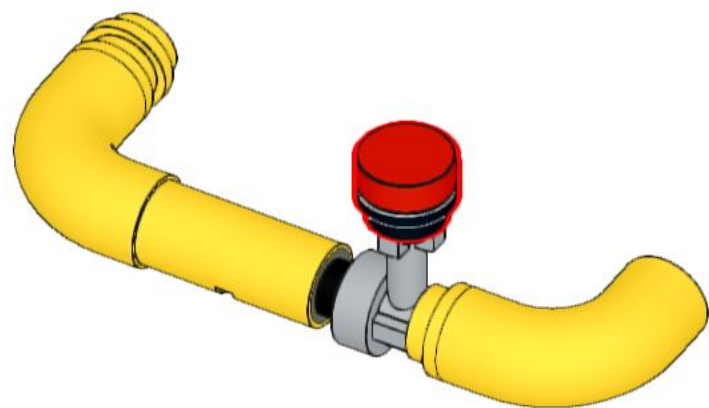
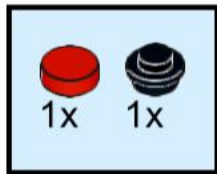

93

IOR FJB 

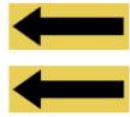
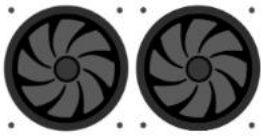

FJB 

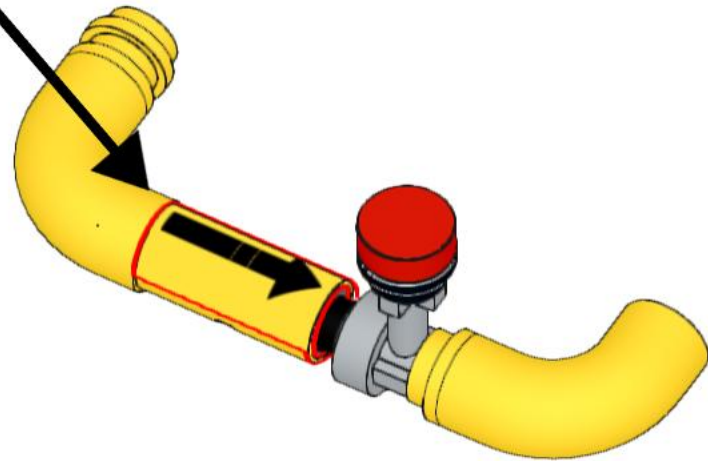

94

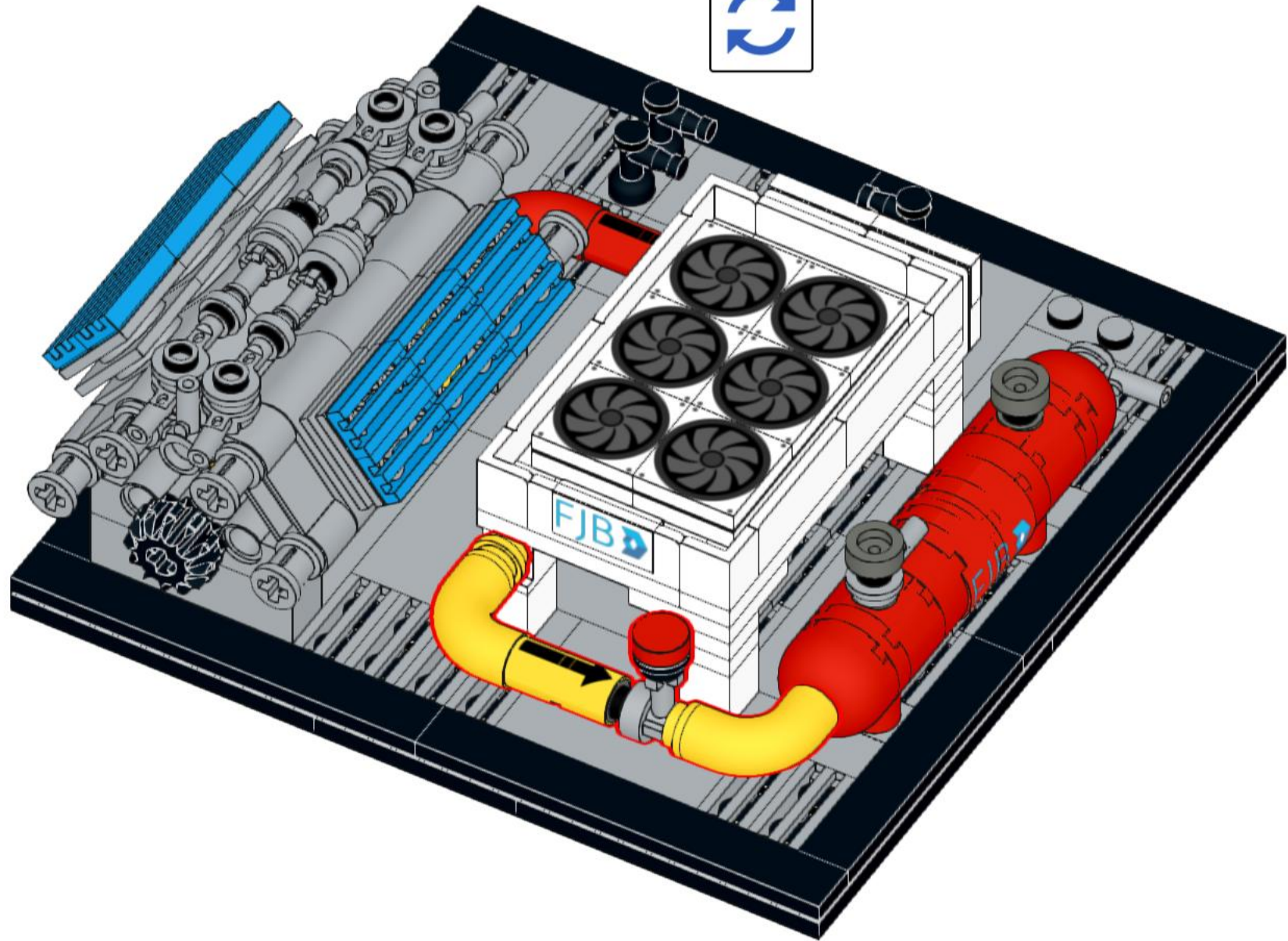

95

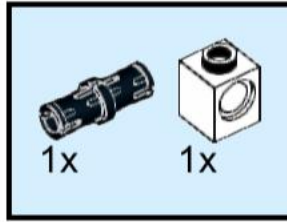

EXPANSION VALVE

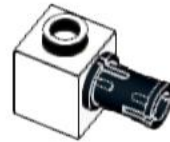
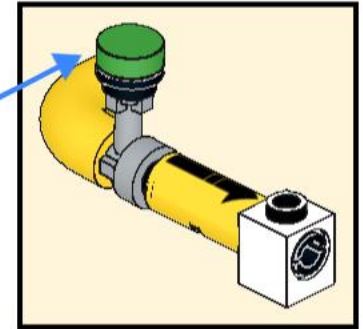

The Expansion Valve

The Expansion Valve reduces the pressure of the liquid refrigerant to change from a high pressure liquid to low pressure liquid before the reaching the evaporator. The Expansion Valve works much like an aerosol can, in that, the compressed liquid in the can is released though a small hole (restrictor) into a larger space where it expands - reducing in pressure. As the liquid reduces in pressure it also cools down.

96

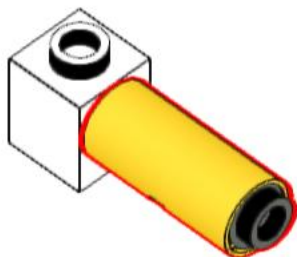
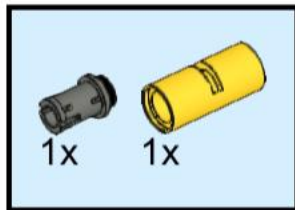

97

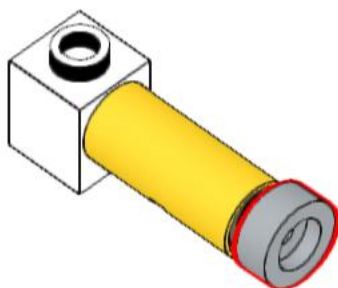
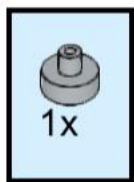

98

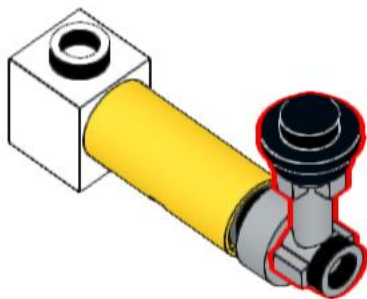

99

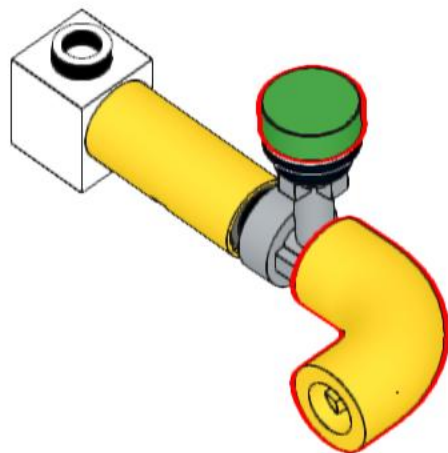
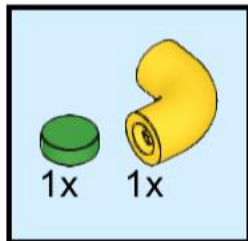

100

IOR FJB Demonhunter BRICKS

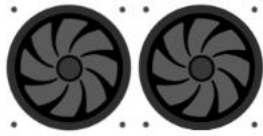

FJB

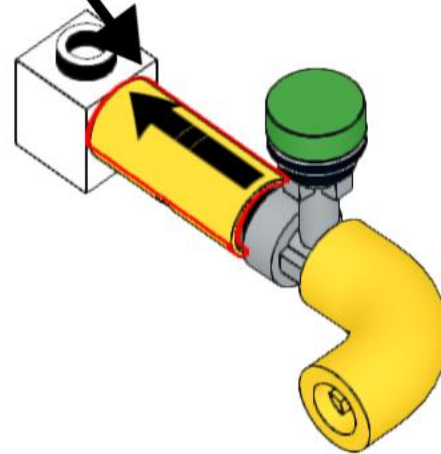

101

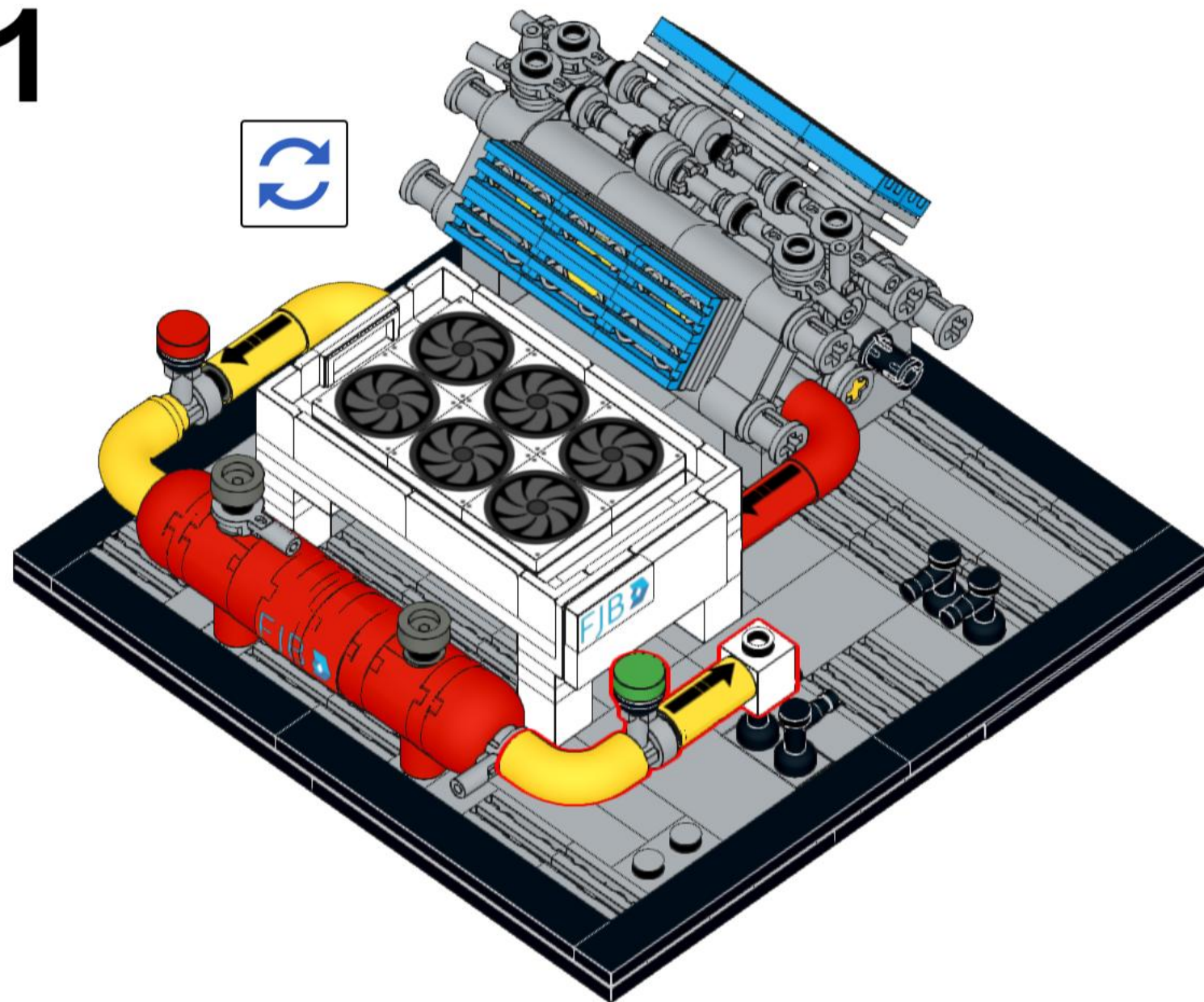

102

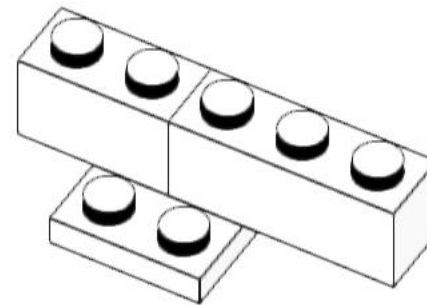
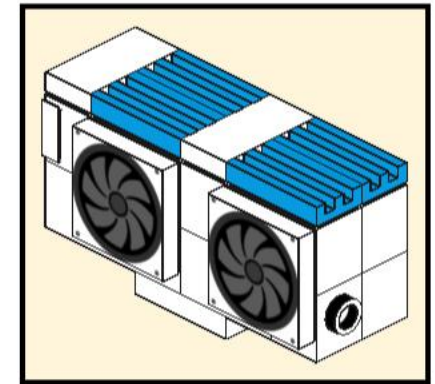
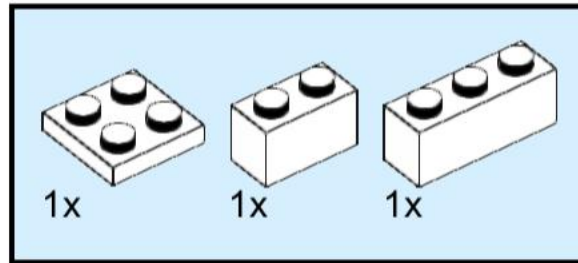

The Evaporator

The Evaporator works on the principle that evaporation of a liquid gives a cooling effect, much like sweat on your skin. The Refrigerant enters the Evaporator from the Expansion Valve as a low pressure liquid/gas vapour mix which absorbs heat from the 'inside air' of the chamber, into the refrigerant. The refrigerant absorbs heat as it undergoes 'change of state' from a liquid into a gas creating a 'cooling effect'.

103

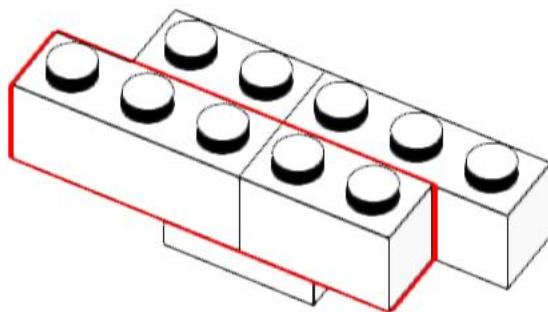
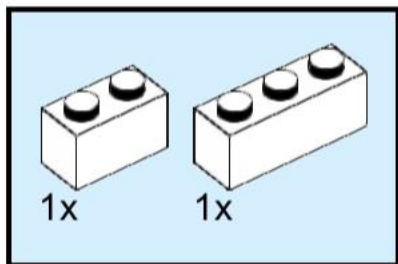

104

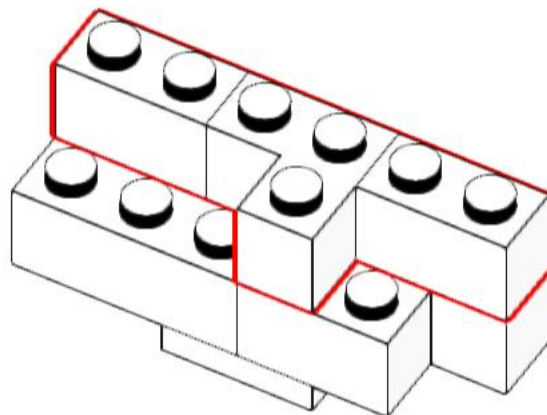
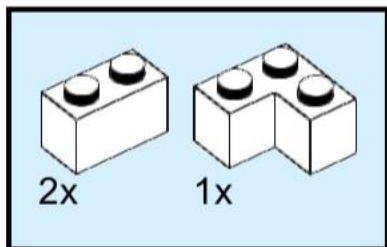

105

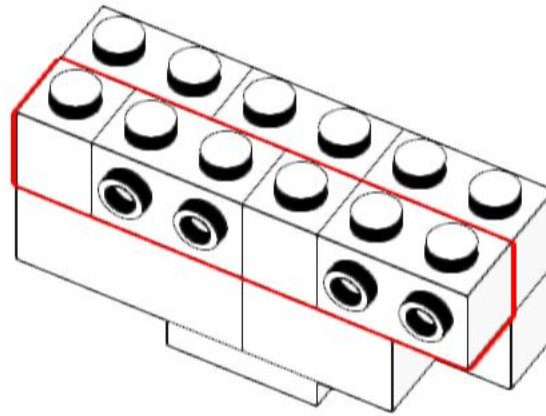
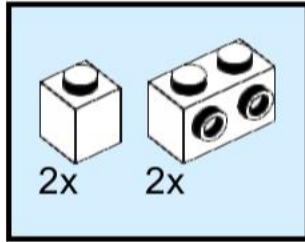

106

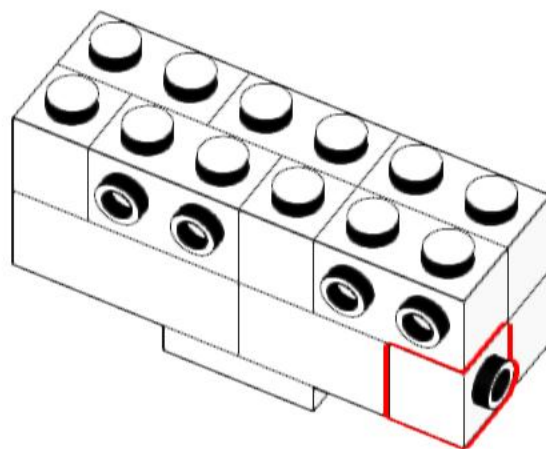
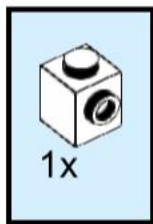

107

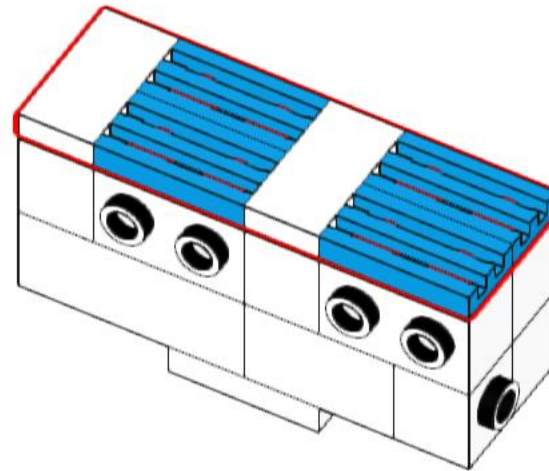
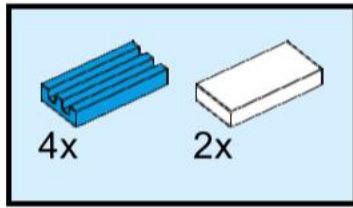

108

IOR FJB 

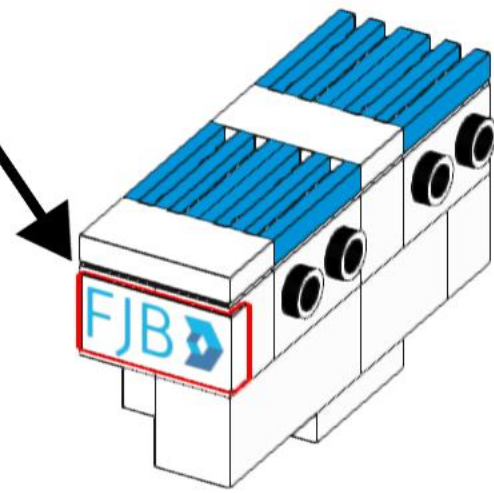
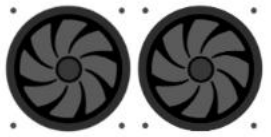

109

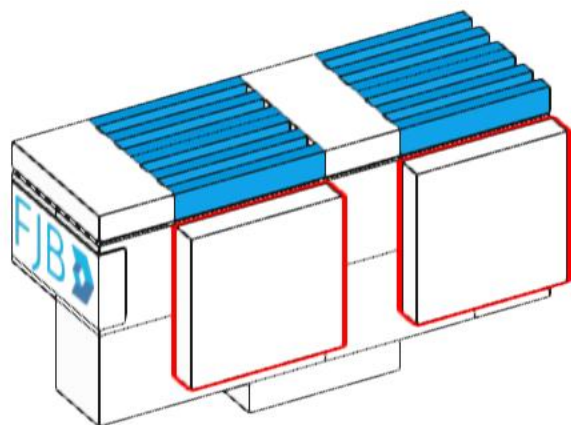
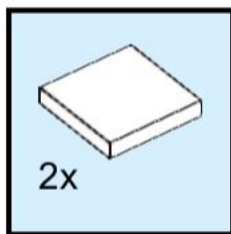

110

IOR FJB 

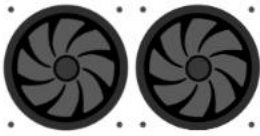

x2

Evaporator fans transfer heat from the room (inside air) into the refrigerant creating a 'cooling effect'.

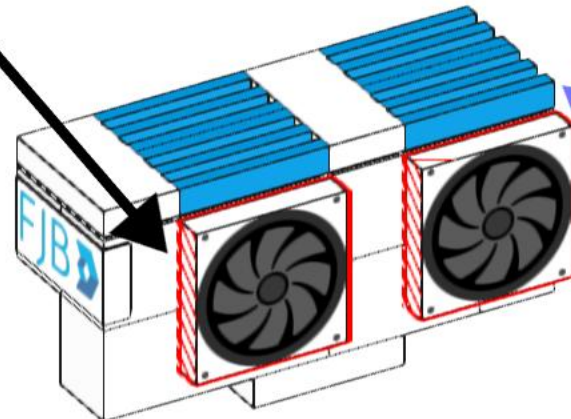

111

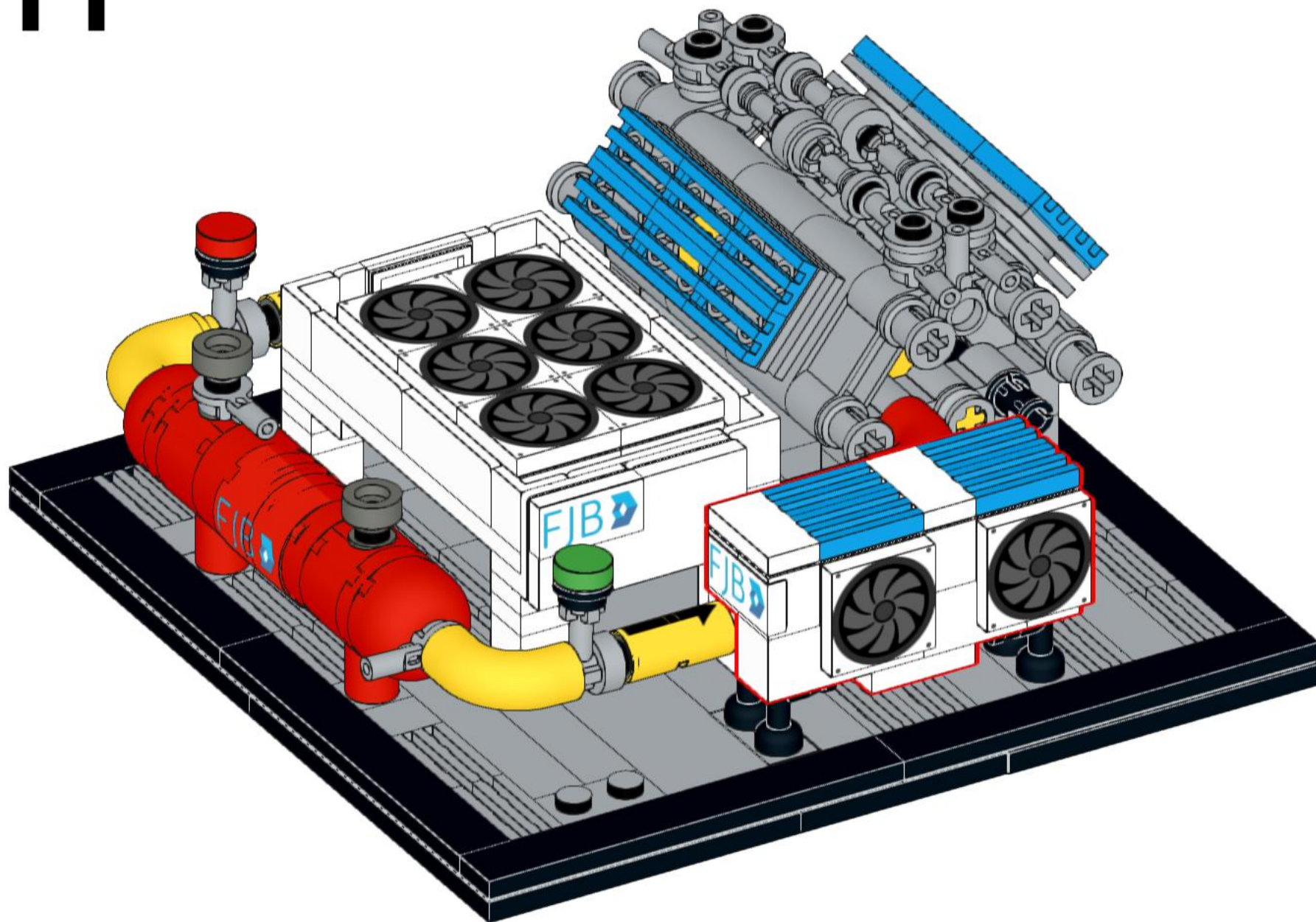

112

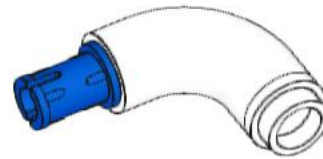
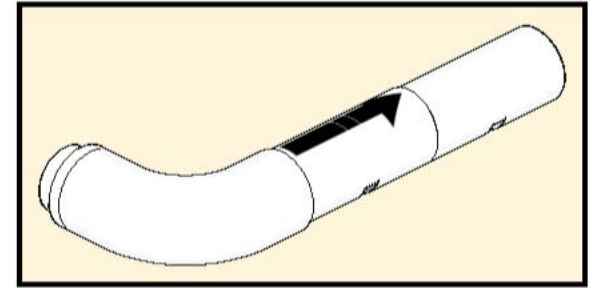
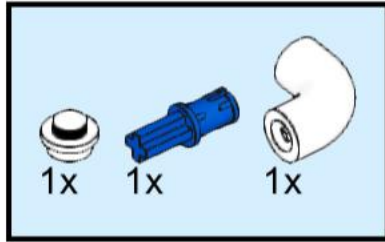

Adding the Suction Line

The Suction Line moves the Refrigerant as gas from the Evaporator back to the Compressor. The Refrigeration Cycle repeats itself.

113

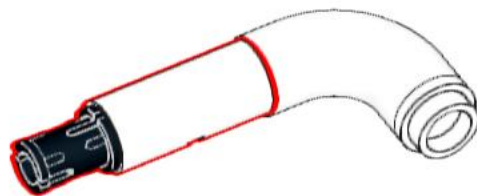
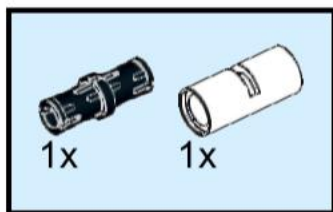

114

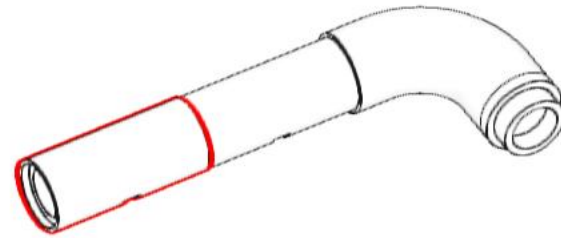
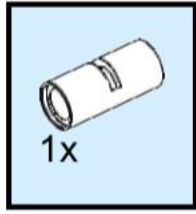

115

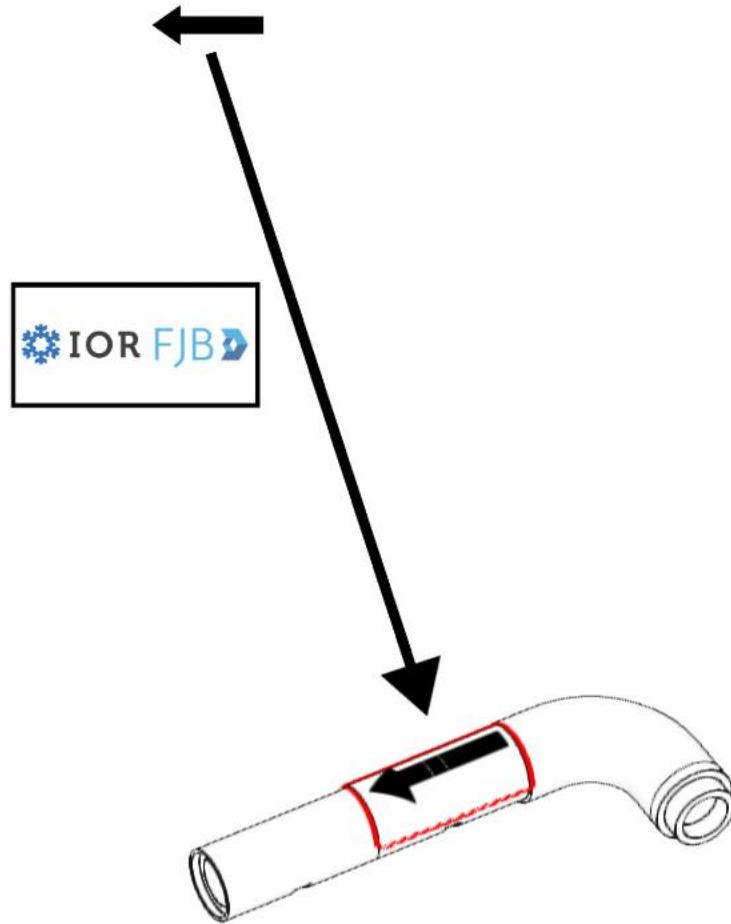

116

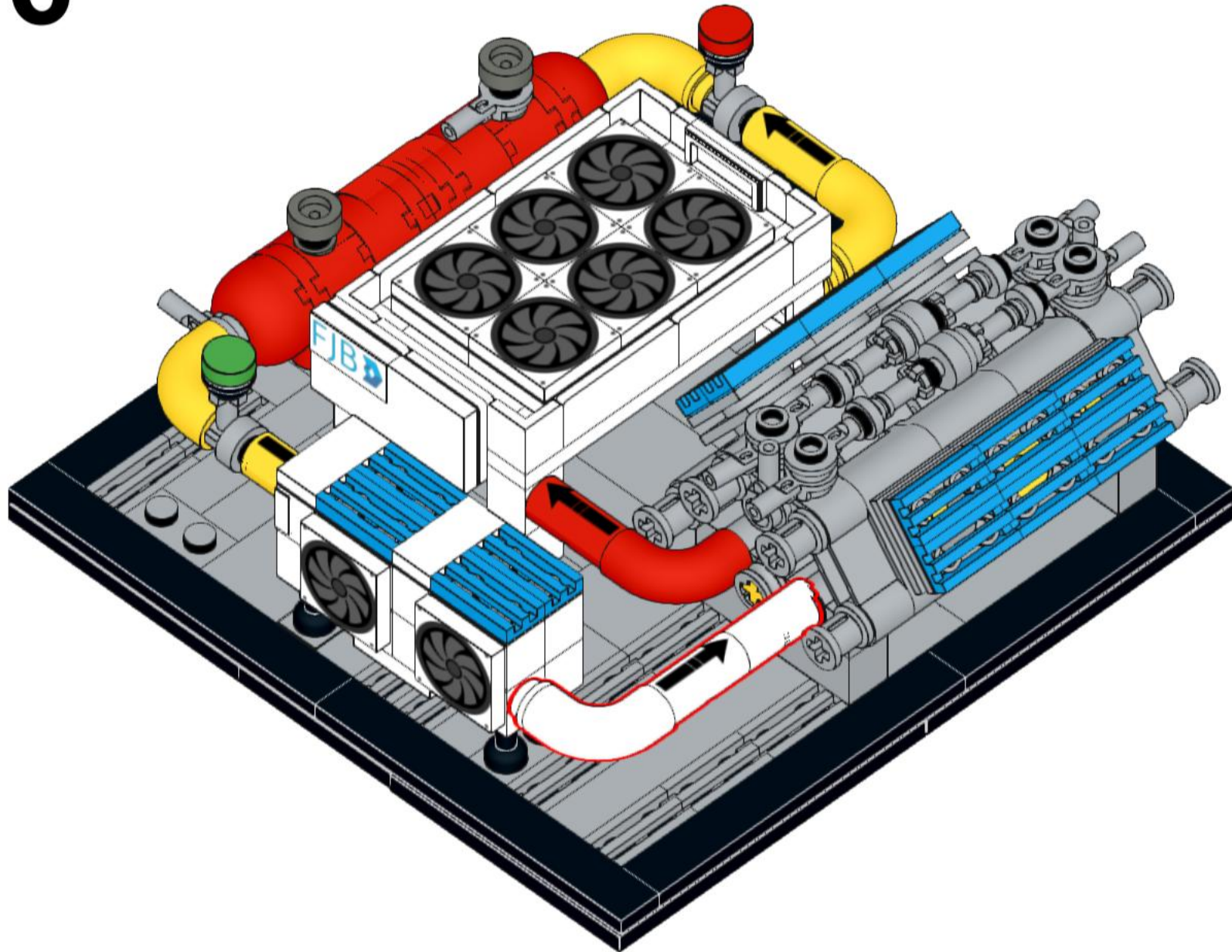

117

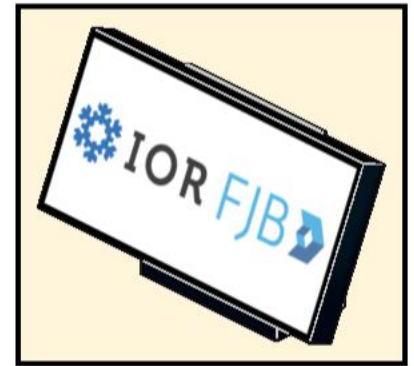
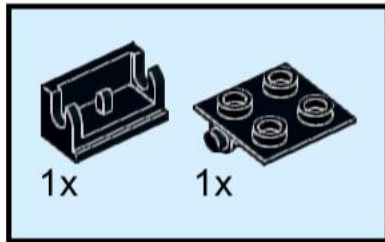

118

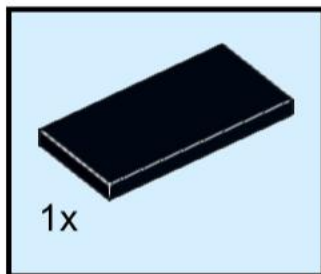

119

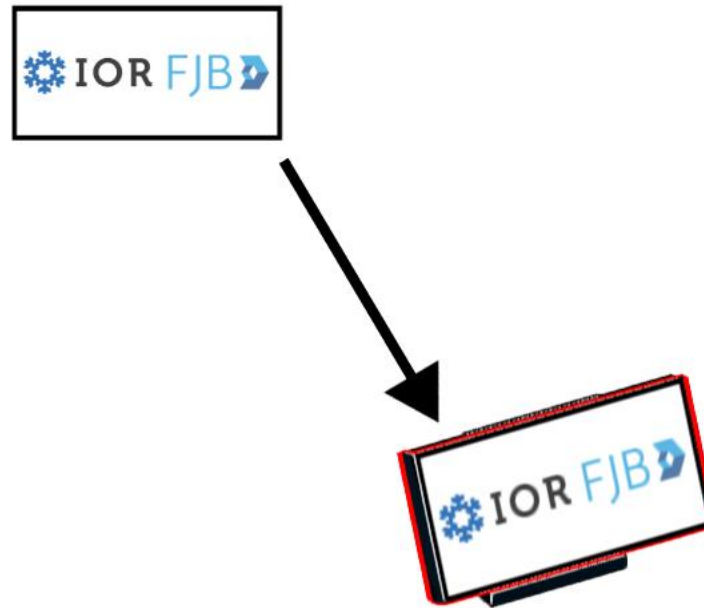

120

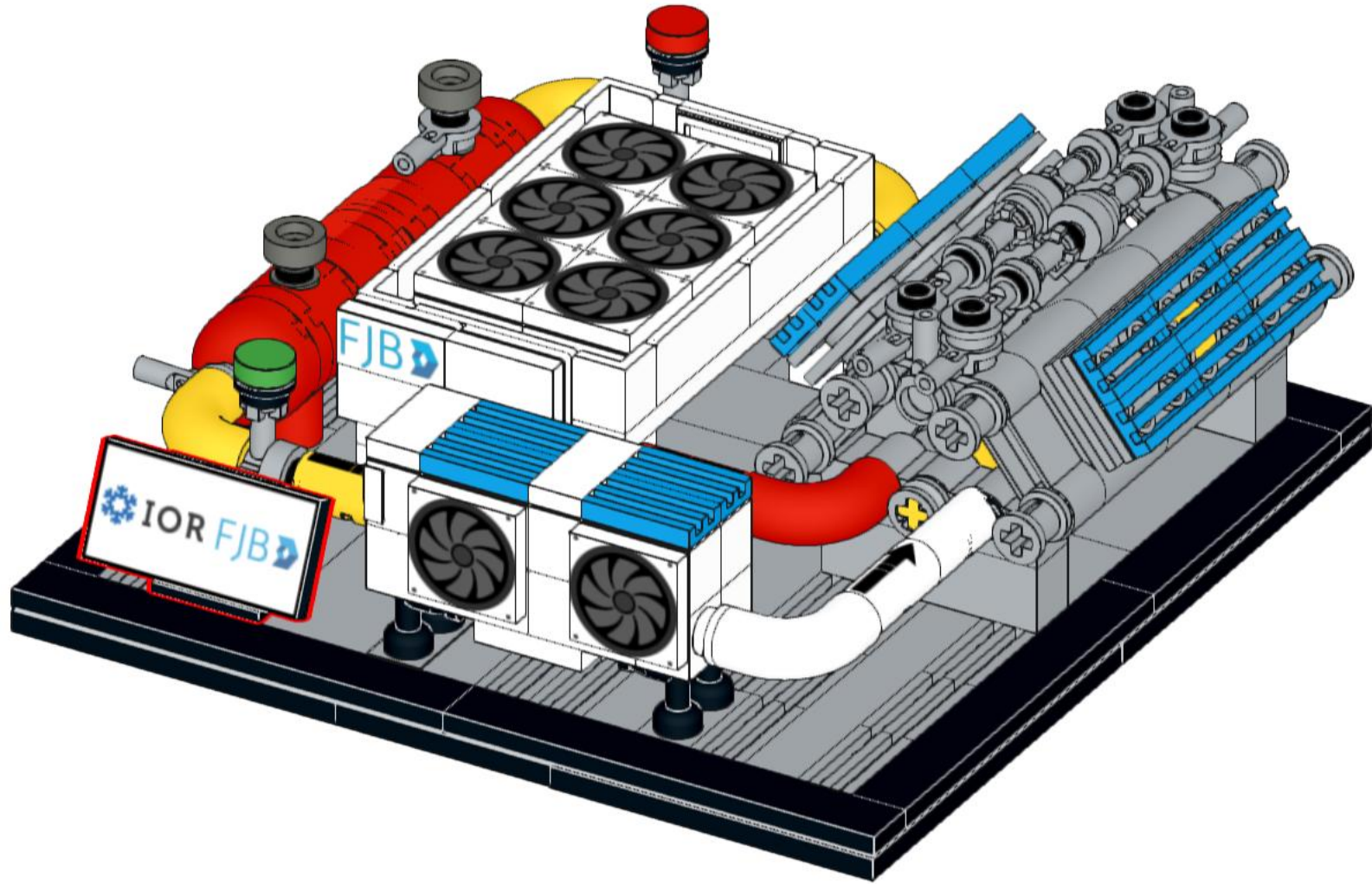

Congratulations – you have built a Single-stage Refrigeration Plant!

